

## Sommaire

Article	Page	Article	Page	Article	Page
Anneau de fixation	42	Mini-Terminaison à tête fraisée	21	Tendeur à cage ouverte à 2 crochets	65
Anneau fileté	66	Mini-Terminaison à vis à chape	25	Tendeur à cage ouverte à 2 oeils	65
Anneau taraudé	66	Mini-Terminaison à vis à œil	25	Tendeur à cage ouverte à œil et crochet	65
Arrêt butoir	44	Mini-Terminaison à vis à tige filetée	25	Terminaison à chape, montage manuel	26
Arrêt d'extrémité	45	Mini-Terminaison à vis tarudée	25	Terminaison à chape, standard	20
Arrêt multi-angles poteau plat	39	Mini-Terminaison simple	18	Terminaison à œil, montage manuel	26
Arrêt multi-angles poteau rond	39	Mini-Terminaison taraudée	22	Terminaison à œil, standard	22
Attache cornière		Mini-Terminaison type KW	19	Terminaison à tige filetée,	
pour support de rayonnage	48	Mini-Terminaison type KW filetage long	19	montage manuel	26
Attache plate pour		Mini-Tige filetée à chape	34	Terminaison conique tarudée,	
support de rayonnage	48	Mini-Tige filetée à œil	34	montage manuel	26
Boule taraudée	45	Mousqueton	66	Terminaison cylindrique	42
Cache Inox	54			Terminaison simple, standard	18
Cage de ridoir pour Mini et Super-Mini	31	Œil fileté	46	Terminaison tarudée à droite,	
Cage de ridoir, standard	31	Œil taraudé	46	montage manuel	25
Cale d'épaisseur pour serre-câble de fix.				Tige filetée	61
d'angle	36	Pince coupante pour câble	27	Tige filetée à œil, standard	34
Capuchon de douille	42	Piton à œil fileté	62		
Chaîne, maille courte	67	Positionneur d'angle multiple, poteau plat	38	Vis Allen tête basse DIN 6912	60
Chaîne, maille longue	67	Positionneur d'angle multiple, poteau rond	38	Vis Allen tête fraisée DIN 7991	60
Chape à émerillon	35			Vis à double filet bois/métaux	61
Chape à visser	35	Ridoir 2 chapes, standard	31	Vis à œil DIN 444, filetage bois	62
Console murale std -		Ridoir 2 terminaisons simples, standard	28	Vis à œil DIN 444, filetage métrique	62
pour chape ou terminaison	54	Ridoir chape et terminaison simple,		Vis cruciforme pour bois aggloméré	60
Console petit modèle	55	standard	29	Vis six pans à bois DIN 571	60
Console type Y	55	Ridoir œil et terminaison simple,			
Cosse	64	standard	32		
		Rondelle DIN 125, forme A	62		
Déco-douille de tension	43	Rondelle spéciale pour poteau rond	39		
Display-support	50	Rosace	54		
Douille à œil	56				
Douille à visser	42	Serre-câble à étrier, série légère	64		
Douille de tension	35	Serre-câble à étrier, série lourde	64		
		Serre-câble croisé, 3 D	52		
Ecrou anti-desserrage DIN 985	63	Serre-câble croisé, multi-angles	53		
Ecrou à six pans DIN 934	63	Serre-câble croisé, multi-angles,			
Ecrou bas à six pans DIN 439	63	fixation murale	53		
Ecrou borgne DIN 1587	63	Serre-câble croisé, multi-angles,			
Élément de protection et de déviation	56	fixation murale avec 1 déviation à œil	53		
		Serre-câble croisé, multi-angles, fixation			
Goujon	61	murale avec 2 déviations à œil	53		
		Serre-câble croisé simple avec fixation			
Maillon rapide	66	murale M 8	52		
Manchon serre-câble	27	Serre-câble croisé simple avec fixation			
Manchon de tension	35	murale M 12	52		
Manille droite	67	Serre-câble de fixation	36		
Manille lyre	67	Serre-câble de fixation à rotule	36		
Maxi-Terminaison	75	Serre-câble de fixation d'extrémité	36		
Maxi-Terminaison à chape, usinée	75	Serre-câble plat, 1 boulon	64		
Maxi-Terminaison à chape, soudée	75	Serre-câble plat, 2 boulons	64		
Maxi-Terminaison à œil	76	Super-Mini-Cage de ridoir longue	30		
Maxi-Chape filetée, usinée	76	Super-Mini-Ridoir chape			
Maxi-Chape filetée, soudée	76	et terminaison simple	29		
Maxi-Œil	77	Super-Mini-Ridoir chape			
Maxi-Corps de ridoir	77	et terminaison simple long	30		
Maxi-Ecrous	77	Super-Mini-Ridoir 2 chapes long	30		
Maxi-Ridoir chape (usinée)		Super-Mini-Ridoir 1 terminaison simple	33		
et terminaison	78	Super-Mini-Ridoir 2 terminaisons simples	28		
Maxi-Ridoir chape (soudée)		Super-Mini-Ridoir 2 terminaisons			
et terminaison	78	simples long	30		
Maxi-Ridoir œil et terminaison	78	Super-Mini-Terminaison à chape	20		
Maxi-Ridoir deux terminaisons	79	Super-Mini-Terminaison à tête bombée	21		
Maxi-Ridoir deux chapes (usinée)	79	Super-Mini-Terminaison à tête fraisée	21		
ASS Maxi-Ridoir deux chapes (soudée)	79	Super-Mini-Terminaison simple	19		
Mini-Chape tarudée	35	Super-Mini-Terminaison simple filetage			
Mini-Ridoir 1 chape	33	long	19		
Mini-Ridoir 1 terminaison simple	33	Super-Mini-Tige filetée à chape longue	34		
Mini-Ridoir 2 chapes	31	Support à chape	51		
Mini-Ridoir 2 terminaisons simples	28	Support de rayonnage	48		
Mini-Ridoir chape et terminaison simple	29	Suspension monobrin avec bague	40		
Mini-Ridoir œil et terminaison simple	32	Suspension monobrin avec boulon à œil	41		
Mini-Ridoir tige filetée		Suspension multibrins	41		
et terminaison simple	32	Système de suspension	70		
Mini-Terminaison à chape	20				
Mini-Terminaison à œil	22				

Article	Page	Article	Page	Article	Page
Angle for ASS Shelf Support	48	Piggyback clip	56	Special washer	39
Angle Positioner for flat posts	38	Plain jaw	35	Stopper	44
Angle Positioner for round posts	38	Quick link	66	Strap for ASS Shelf Support	48
Angle Stopper for flat posts	39	Rigging Screw - body, Maxi type	77	Stud	61
Angle Stopper for round posts	39	Rigging Screw, Maxi type	78	Swivel jaw	35
Attaching clip	36	with eye and terminal	78	Tensioning nipple	35
Attaching clip corner unit	36	Rigging Screw, Maxi type	78	Tensioning nut	35
Attaching rop coupler	36	with jaw (machined) and terminal	78	Tensioning unit for decoration purposes	43
Attaching sleeve	42	Rigging Screw, Maxi type	78	Thimble	64
Ball	45	with jaw (welded) and terminal	78	Threaded eye, Maxi type	77
Capped nut DIN 1587	63	Rigging Screw, Maxi type	79	Threaded eye, Mini type	34
Clamping jaw	51	with terminal and terminal	79	Threaded eye, Standard type	34
Clamping ring	42	Rigging Screw, Maxi type	79	Threaded jaw, Mini type	34
Cone terminal, Mini type	21	with jaw and jaw (machined)	79	Threaded jaw, Super-Mini type, long	34
Cone terminal, Super-Mini type	21	Rigging Screw, Maxi type	79	Threaded rod	61
Countersunk bolt		with jaw and jaw (welded)	79	Threaded terminal type KW, Mini type	19
with hexagon socket head	60	Rigging Screw, Mini type,	32	Threaded terminal type KW, Mini type, extra long	19
Cover washer	54	with eye and terminal	32	Threaded terminal with internal thread	26
Cross recessed chipboard screw	60	Rigging Screw, Mini type,	31	Threaded terminal with outside thread	26
Cross-over clip	53	with jaw and jaw	31	Threaded terminal, Maxi type	75
Cross-over clip 3D	52	Rigging Screw, Mini type,	29	Threaded terminal, Mini type	18
Cross-over clip M 8, simple	52	with jaw and terminal	29	Threaded terminal, Mini type, with internal thread	22
Cross-over clip with connection to the wall	53	Rigging Screw, Mini type,	33	Threaded terminal, Standard type	18
Cross-over clip with connection to the wall and eye connector	53	with one terminal	33	Threaded terminal, Super-Mini type	19
Cross-over clip with connection to the wall and two eye connectors	53	Rigging Screw, Mini type,	32	Threaded terminal, Super-Mini type, with long thread	19
Cross-over clip, simple	52	with terminal and terminal	32	Turnbuckle similar to DIN 1480 with stub ends	65
Cylindrical rope clip	27	Rigging Screw, Mini type,	32	Turnbuckle with eye and eye	65
Cylindrical screw		with rod and terminal	32	Turnbuckle with hook and eye	65
with hexagon socket head	60	Rigging Screw, Standard type,	32	Turnbuckle with hook and hook	65
Cylindrical terminal	42	with eye and terminal	32	Wall bracket, small type	55
Display clip	50	Rigging Screw, Standard type,	31	Wall bracket, connection with jaws	54
Dome head terminal, Super-Mini type	21	with jaw and jaw	31	Wall bracket, for threaded terminal	54
Duplex clip	64	Rigging Screw, Standard type,	29	Wall bracket, Y type	55
End stop for ASS Attaching clip	36	Rigging Screw, Standard type,	28	Wall stud	61
End stop	45	with two terminals	28	Wall/Ceiling Eye nut	46
Eye bolt	46	Rigging Screw, Super-Mini type,	30	Washer DIN 125, Form A	52
Eye bolt with right hand thread	66	with two jaws, long type	30	Welded Jaw Terminal, Maxi type	75
Eye bolts according to DIN 444 with metric thread	62	Rigging Screw, Super-Mini type,	29	Welded Threaded Jaw, Maxi type	76
Eye bolts according to DIN 444 with wood thread	62	with jaw and terminal	29	Wire rope clip, heavy pattern	64
Eye nut	66	Rigging Screw, Super-Mini type,	30	Wire rope clip, light pattern	64
Eye terminal for self assembly	26	with one terminal	33	Wire rope cutters	73
Eye terminal, Maxi type	76	Rigging Screw, Super-Mini type,	28		
Eye terminal, Mini type	22	with two terminals	28		
Eye terminal, Standard type	22	Rigging Screw, Super-Mini type,	30		
Hanging System	70	with two terminals, long type	30		
Hanging unit, multiple	41	Rigging Screw-body,	31		
Hanging unit, simple type		for Mini and Super-Mini type	31		
with attaching sleeve	40	Rigging Screw-body, Standard type	31		
Hanging unit, simple type with eye bolt	41	Rigging Screw-body, Super-Mini type,	30		
Hexagon lock nut DIN 439	63	long type	30		
Hexagon nut DIN 934	53	Rose	54		
Hexagon wood screw acc. to DIN 571	60	Screw terminal for self assembly	25		
Jaw terminal for self assembly	26	Screw terminal with eye, Mini type	25		
Jaw terminal, Mini type	20	Screw terminal with internal thread,	25		
Jaw terminal, Standard type	20	Mini type	25		
Jaw terminal, Super-Mini type	20	Screw terminal with jaw, Mini type	25		
Jaw, Mini type with internal thread	35	Screw terminal with outside thread,	25		
Locking cap	42	Mini type	25		
Lock Nut, Maxi type	77	Self-locking hexagon nut acc. to DIN 985	63		
Long link chain	67	Shackle, anchor type	67		
Machined Jaw Terminal, Maxi type	75	Shackle, U-type	67		
Machined Threaded Jaw, Maxi type	76	Shank collared eye bolt, long type	62		
		Shelf Support	48		
		Short link chain	67		
		Simplex clip	64		
		Sleeve with eye connector	56		
		Snap hook	66		







# ASS<sup>®</sup>

## SUPER-MINI

*La tendance actuelle  
du système de décoration*  
*An uptodate ornamental system*



*La finesse au service  
de la robustesse*

*The best things come in a  
small package*

[www.lemmens-cables.be](http://www.lemmens-cables.be)  
[info@lemmens-cables.be](mailto:info@lemmens-cables.be)



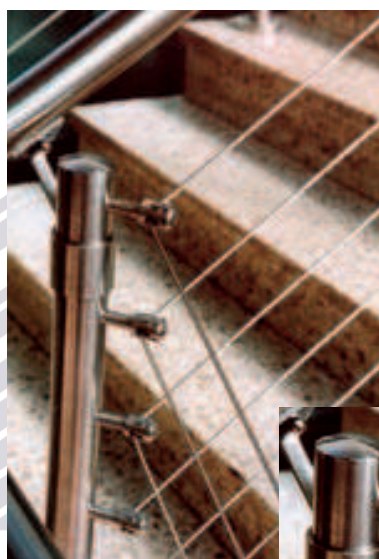
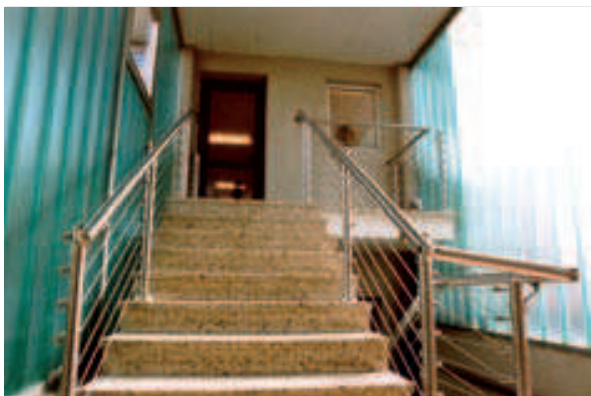



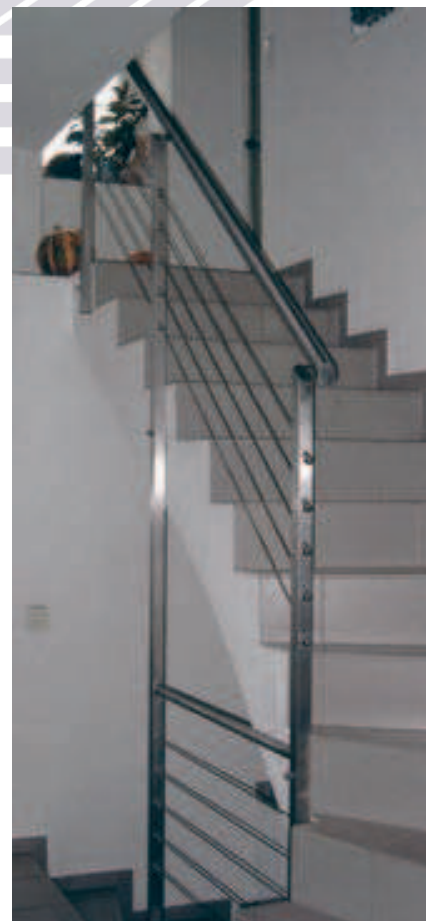
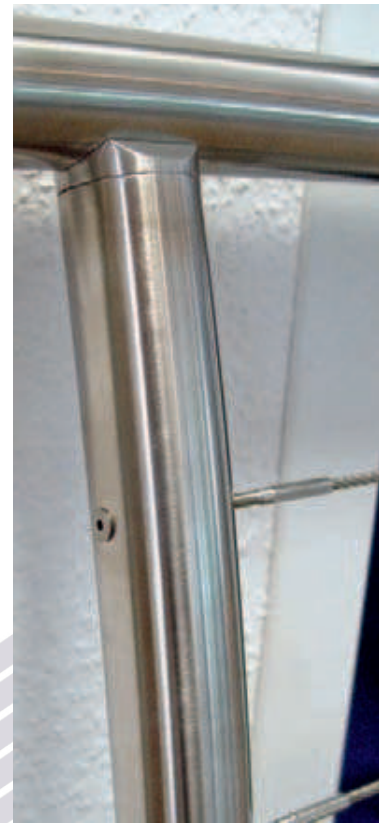







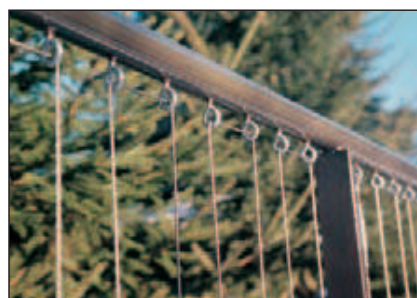
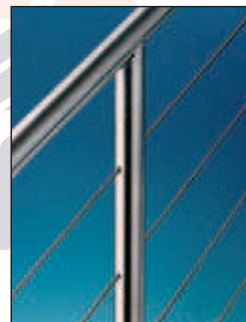
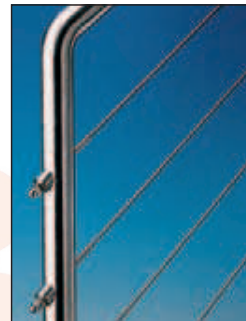











## CHARGES DE RUPTURE DES CÂBLES MUNIS DE TERMINAISONS SERTIES (STANDARD, MINI ET SUPERMINI)

Ø câble mm	Câble similaire EN 12385-4 6x7 avec âme métallique classe de résistance 1570 N/mm <sup>2</sup> AISI 316 kN	Câble similaire EN 12385-4 6x19 M avec âme métallique classe de résistance 1570 N/mm <sup>2</sup> AISI 316 kN
2	2,02	1,87
3	4,56	4,23
4	8,09	7,47
5	12,64	11,68
6	18,27	16,85
7	24,84	22,95
8	32,49	30,02
10	50,67	46,89



D'autres classes de câbles et/ou d'autres constructions peuvent engendrer d'autres charges de rupture. L'utilisation de câbles de ruptures plus élevées peut avoir pour conséquence une diminution de la charge de rupture donnée. Les charges de ruptures se rapportent à des essais statiques sous réserve d'un sertissage correct. **Elles correspondent à 90% de la charge de rupture des câbles.**

## DIAMETRE EXTERIEUR DES TERMINAISONS AVANT/APRES SERTISSAGE

Ø câble mm	Standard et Mini diamètre extérieur		Super-Mini diamètre extérieur	
	Avant mm	Après mm	Avant mm	Après mm
2	---	---	4,5	3,95 - 4,2
3	6,3	5,4 - 5,7	5,4	4,5 - 4,8
4	7,5	6,4 - 6,7	6,5	5,4 - 5,7
5	9,0	7,8 - 8,2	7,5	6,4 - 6,7
6	12,5	10,8 - 11,1	9,0	7,8 - 8,2
7	14,2	12,6 - 12,9	---	---
8	16,0	14,0 - 14,3	12,5	10,8 - 11,1
10	18,0	15,5 - 15,8	---	---



Les valeurs indiquées dans les colonnes „Après“ du tableau ci-dessus s'expliquent par l'ovalisation de la terminaison après sertissage. Ces valeurs sont le résultat des cotes relevées avant les essais de rupture. Le diamètre minimum, après sertissage, ne devra pas dévier de plus de 0,1 mm de la valeur inférieure.



**Veillez noter que nos terminaisons ne peuvent être serties qu'avec des presses à galets ou à matrices.**

Sertissage d'une terminaison simple à l'aide d'une presse à galets



Les essais effectués sur des bancs de traction modernes assurent une qualité de production sûre.



Essai de rupture d'un ridoir.



## CHARGES DE RUPTURE DES RIDOIRS A CHAPE, A ŒIL ET/OU A TIGE FILETEE S.A.

Ø filetage	diamètre du câble utilisé avec			Standard, Mini-, Super-Mini Charge de rupture kN
	Standard mm	Mini mm	Super-Mini mm	
M 4	---	---	3	4,55
M 5	2,5	3	4	8,15
M 6	3	4	5	12,60
M 8	4	5	6	18,20
M 10	5	6	8	32,40
M 12	6	8	---	40,00
M 14	7	---	---	55,00
M 16	8	10	---	65,00
M 20	10	---	---	85,00



Les valeurs indiquées sont également valables pour les pièces détachées des ridoirs. Les charges de rupture se rapportent à des essais statiques. **Dans le cas de ridoirs à 1 ou 2 terminaisons à sertir, la charge de rupture est donnée par les terminaisons.**



Les charges de rupture reposent sur les contrôles courants de nos produits réalisés sur des bancs d'essais validés par un organisme officiel. (Materialprüfungsamt Nordrhein-Westfalen).

En outre, les terminaisons à sertir (de 3 à 10 mm) ainsi que les ridoirs (à chape ou à œil) qui figurent dans ce catalogue, ont été testés par la société Deutsche Montan Technologie GmbH (DMT) Geschäftsfeld Bergbau Service Seil- & Fördertechnik (anciennement Seilprüfstelle Bochum).

Ces valeurs servent de références.



## Instructions pour un sertissage correct des terminaisons

### Presse / Presse à Galets

#### STANDARD et ASSMINI

seront sertis avec les matrices ou les galets habituels recommandés par le fabricant de la presse.

#### ASSSUPER-MINI

seront sertis avec les matrices ou les galets du diamètre inférieur.

Ex. : ASSSUPER-MINI Ø câble 4 mm avec les matrices ou les galets Ø câble 3 mm  
Ø câble 3 mm avec les matrices ou les galets Ø câble 2,5 mm

Attention : les Ø câbles 8 mm sont à sertir avec les matrices ou galets de 6 mm standard pour les Ø câbles de 2 mm, il faut un outillage spécial

ASSMINI et ASSSUPER-MINI ne nécessitent pas d'investir dans de nouveaux outillages.

### Positionnement

Veuillez vous référer au croquis ci-dessous.

Valable pour toute sorte de presse

Pas de bourrelet après le sertissage des ASSSUPER-MINI.

ASSSUPER-MINI = Attractif, Solide et Sûr.

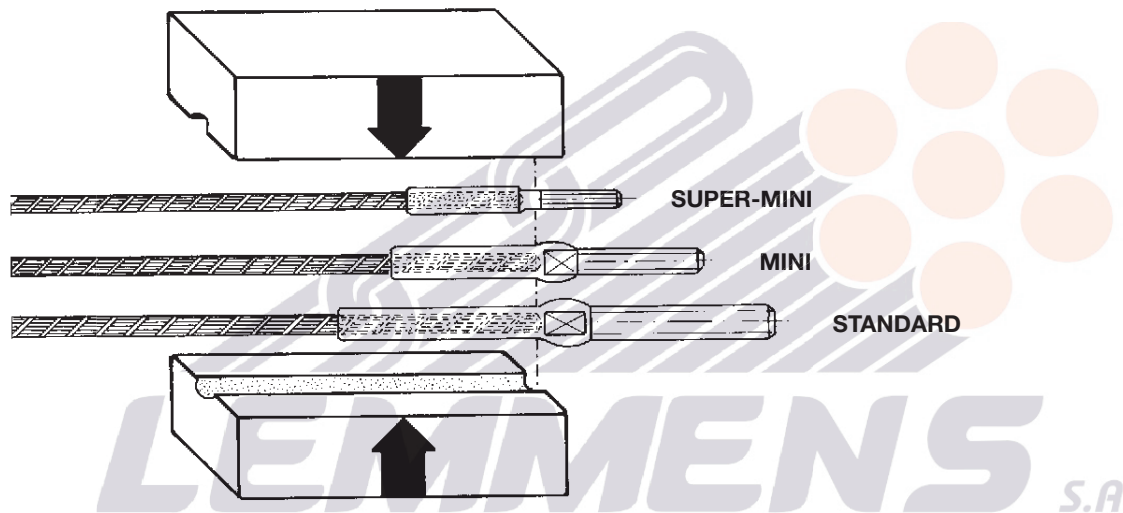

## Instructions for the correct pressing/rolling of threaded terminals

### Pressing/Rolling

#### Standard and ASSMini type

Use the standard dies/swages as recommended by the machine manufacturer.

#### ASSSuper-Mini

as a rule use the next size die/swage down, e.g.

ASSSuper-Mini type for Ø 4 mm use die/swage for Ø 3 mm rope.  
Ø 3 mm use die/swage for Ø 2,5 mm rope.

Attention: Ø 8 mm use die/swage for Ø 6 mm standard.  
For pressing/rolling of ASSSUPER-MINI terminals for Ø 2 mm as special tool is required.

Standard dies/swages are used for the ASSMini and ASSSuper-Mini type (besides Ø 2 mm).

Please see above drawing for the positioning of wire rope and terminal before pressing.

The same criteria applies for both pressing and roll swaging.

There should be no flash after pressing/roll swaging the ASSSuper-Mini.

ASSSuper-Mini = Aesthetic, Strong, Safe

### Construction des câbles

7 x 7 suivant DIN 3055  
7 x 19 suivant DIN 3060

1 x 19 suivant DIN 3053

### Important !

Tout changement de cote nous est réservé. Dans le besoin de cotes plus précises, veuillez nous consulter.

Avec la parution de ce catalogue toutes les anciennes cotes sont périmées.

### Rope constructions

7 x 7 according to DIN 3055  
7 x 19 according to DIN 3060

1 x 19 according to DIN 3053

### Important note!

All dimensions are subject to change without notice. If exact dimensions are required please reconfirm with us.

This edition supercedes all previous editions.



Sous réserve d'un sertissage correct, les données techniques se rapportent à des charges statiques et non des charges dynamiques.

*This information is based on static and not on dynamic loads, assuming correctly swaged terminals.*

#### **Charge de rupture des terminaisons serties**

#### **Breaking load limit of terminals swaged on a wire rope**

##### **STANDARD**

≥ 90 % de la rupture du câble  
 ≥ 90 % of the minimum breaking load of the rope

##### **MINI**

≥ 90 % de la rupture du câble  
 ≥ 90 % of the minimum breaking load of the rope

##### **SUPER-MINI**

≥ 90 % de la rupture du câble  
 ≥ 90% of the minimum breaking load of the rope

**Attention ne pas confondre la charge de rupture avec la charge utile.**

*Please do not mix up breaking load limits with working load limits.*

Ces résultats reposent sur des essais avec des câbles 7 x 7 suivant DIN 3055 et 7 x 19 suivant DIN 3060.

*These results are based on breaking tests with wire ropes 7 x 7 according to DIN 3055 and 7 x 19 according to DIN 3060.*



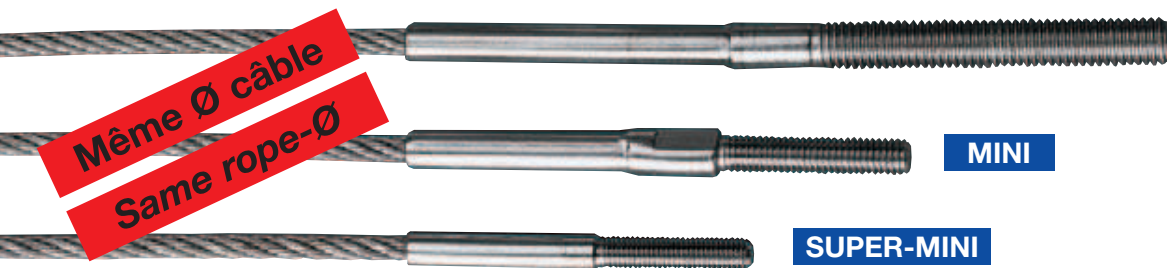

**STANDARD**

**MINI**

**SUPER-MINI**

**UN** diamètre câble - **TROIS** générations de terminaisons  
*One rope diameter - three connector options*

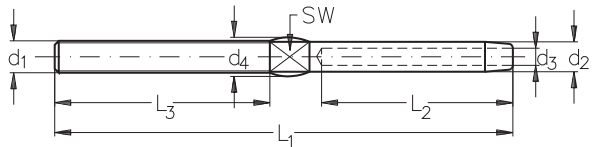

**Terminaison simple INOX**  
 filetage à droite ou à gauche  
 standard

**NIRO Threaded Terminal**  
 with right and left hand thread  
 Standard type

Ø câble rope-Ø mm	Filetage thread d <sub>1</sub>	d <sub>2</sub> mm	d <sub>3</sub> mm	d <sub>4</sub> mm	L <sub>1</sub> mm	L <sub>2</sub> mm	L <sub>3</sub> mm	SW mm	Filetage à droite right hand thread N° article stock no.	Filetage à gauche left hand thread N° article stock no.
2,5	M 5	5,4	2,7	6,5	86	35	40	4	301 010 005	301 011 005
3	M 6	6,3	3,3	7,0	97	38	48	5	301 010 006	301 011 006
4	M 8	7,5	4,3	8,5	115	45	54	6	301 010 008	301 011 008
5	M 10	9,0	5,3	10,5	128	52	61	7	301 010 010	301 011 010
6	M 12	12,5	6,3	13,5	162	63	79	10	301 010 012	301 011 012
7	M 14	14,2	7,3	15,0	178	70	90	12	301 010 014	-
8	M 16	16,0	8,3	17,0	214	80	102	14	301 010 016	301 011 016
10	M 20	17,8	10,5	18,5	215	90	105	15	301 010 020	301 011 020

**LEMMENS** S.A.

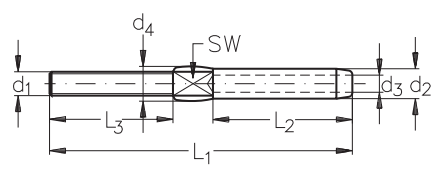

**ASS Mini-Terminaison simple INOX**  
 filetage à droite ou à gauche

**ASS Threaded Terminal, Mini type**  
 with right and left hand thread

DBGM design protégé  
 registered design

Ø câble rope-Ø mm	Filetage thread d <sub>1</sub>	d <sub>2</sub> mm	d <sub>3</sub> mm	d <sub>4</sub> mm	L <sub>1</sub> mm	L <sub>2</sub> mm	L <sub>3</sub> mm	SW mm	Filetage à droite right hand thread N° article stock no.	Filetage à gauche left hand thread N° article stock no.
3	M 5	6,3	3,3	7,0	58	27	25	5	311 010 005	311 011 005
4	M 6	7,5	4,3	8,5	75	35	30	6	311 010 006	311 011 006
5	M 8	9,0	5,3	10,5	80	40	30	7	311 010 008	311 011 008
6	M 10	12,5	6,3	14,0	105	50	40	10	311 010 010	311 011 010
10	M 16	17,8	10,5	17,8	215	88	100	15	311 010 016	-

Attention ! Après sertissage la cote d<sub>4</sub> est la plus épaisse.

Please take the dimension d<sub>4</sub> into consideration which is determined by the pressing.

Sans précision, les articles ci-dessus seront livrés filetés à droite.  
 All items are delivered with right hand thread unless specified otherwise.



**ASS Mini-Terminaison simple type KW**  
filetage à droite ou à gauche

**ASS Threaded terminal type KW, Mini type**  
with right and left hand thread

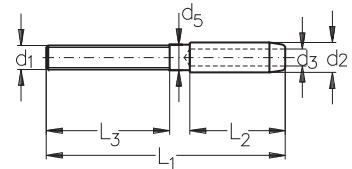

DBGM

Ø câble rope-Ø mm	Filetage thread d <sub>1</sub>	d <sub>2</sub> mm	d <sub>3</sub> mm	d <sub>5</sub> mm	L <sub>1</sub> mm	L <sub>2</sub> mm	L <sub>3</sub> mm	Filetage à droite right hand thread N° article stock no.	Filetage à gauche left hand thread N° article stock no.
3	M 5	6,3	3,3	5,5	48	18	25	311 014 005	311 015 005
4	M 6	7,5	4,3	6,4	59	24	30	311 014 006	311 015 006
5	M 8	9,0	5,3	7,8	68	30	30	311 014 008	311 015 008
6	M 10	12,5	6,3	10,8	84	36	40	311 014 010	311 015 010
8	M 12	16,0	8,3	14,0	115	55	50	311 014 012	311 015 012
10	M 16	17,8	10,5	15,5	142	70	60	311 014 016	311 015 016



**ASS Mini-Terminaison simple type KW**  
filetage long à droite ou à gauche

**ASS Threaded terminal type KW, Mini type**  
with extra long thread, right and left hand

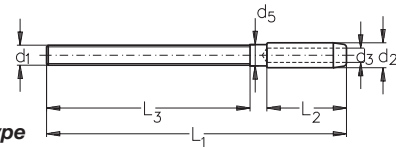

DBGM

Ø câble rope-Ø mm	Filetage thread d <sub>1</sub>	d <sub>2</sub> mm	d <sub>3</sub> mm	d <sub>5</sub> mm	L <sub>1</sub> mm	L <sub>2</sub> mm	L <sub>3</sub> mm	Filetage à droite right hand thread N° article stock no.	Filetage à gauche left hand thread N° article stock no.
3	M 5	6,3	3,3	5,5	73	18	50	311 016 005	311 017 005
4	M 6	7,5	4,3	6,4	89	24	60	311 016 006	311 017 006
5	M 8	9,0	5,3	7,8	98	30	60	311 016 008	311 017 008
6	M 10	12,5	6,3	10,8	124	36	80	311 016 010	311 017 010
8	M 12	16,0	8,3	14,0	165	55	100	311 016 012	311 017 012
10	M 16	17,8	10,5	15,5	202	70	120	311 016 016	311 017 016



**ASS Super-Mini-Terminaison simple**  
filetage à droite ou à gauche

**ASS Threaded Terminal, Super-Mini type**  
with right and left hand thread

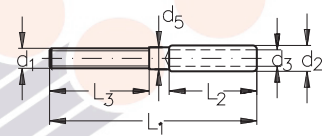

DBP

Ø câble rope-Ø mm	Filetage thread d <sub>1</sub>	d <sub>2</sub> mm	d <sub>3</sub> mm	d <sub>5</sub> mm	L <sub>1</sub> mm	L <sub>2</sub> mm	L <sub>3</sub> mm	Filetage à droite right hand thread N° article stock no.	Filetage à gauche left hand thread N° article stock no.
2	M 3	4,5	2,2	4,0	35	15	15	321 010 003	321 011 003
3	M 4	5,4	3,3	4,6	45	20	20	321 010 004	321 011 004
4	M 5	6,5	4,3	5,5	52	22	25	321 010 005	321 011 005
5	M 6	7,5	5,3	6,4	63	25	30	321 010 006	321 011 006
6	M 8	9,0	6,3	7,8	68	30	30	321 010 008	321 011 008
8	M 10	12,5	8,5	10,8	88	40	40	321 010 010	321 011 010



**ASS Super-Mini-Terminaison simple**  
filetage long à droite ou à gauche

**ASS Threaded Terminal, Super-Mini type**  
with extra long thread, right and left hand

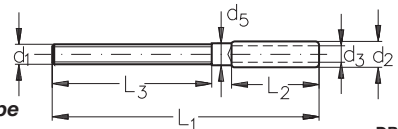

DBP

Ø câble rope-Ø mm	Filetage thread d <sub>1</sub>	d <sub>2</sub> mm	d <sub>3</sub> mm	d <sub>5</sub> mm	L <sub>1</sub> mm	L <sub>2</sub> mm	L <sub>3</sub> mm	Filetage à droite right hand thread N° article stock no.	Filetage à gauche left hand thread N° article stock no.
3	M 4	5,4	3,3	4,6	65	20	40	321 012 004	321 013 004
4	M 5	6,5	4,3	5,5	77	22	50	321 012 005	321 013 005
5	M 6	7,5	5,3	6,4	93	25	60	321 012 006	321 013 006
6	M 8	9,0	6,3	7,8	98	30	60	321 012 008	321 013 008
8	M 10	12,5	8,5	10,8	128	40	80	321 012 010	321 013 010

**Note :** la cote d<sub>5</sub> des Terminaisons KW et des Super-Mini correspond au diamètre après sertissage, d'où absence de bourrelet.

d<sub>5</sub> corresponds for type KW and Super-Mini- type to the diameter after swaging, therefore the shaft is without bulge (see photo). d<sub>5</sub> does not correspond to the diameter of the bore whole in the posts. **The responsible swaging company will give you the required details.**

Sans précision, les articles ci-dessus seront livrés filetés à droite.

All items are delivered with right hand thread unless specified otherwise.



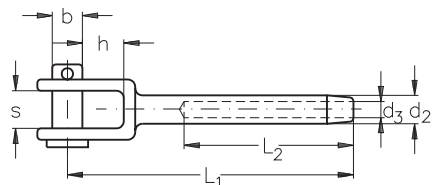

**Terminaison à chape INOX standard**

**NIRO Jaw Terminal Standard type**

Ø câble rope-Ø mm	d <sub>2</sub> mm	d <sub>3</sub> mm	L <sub>1</sub> mm	L <sub>2</sub> mm	h mm	s mm	b mm	N° article stock no.
3	6,3	3,3	67	38	8,5	7	6,0	301 020 003
4	7,5	4,3	76	45	11	10	7,9	301 020 004
5	9,0	5,3	85	52	13	12	9,0	301 020 005
6	12,5	6,3	108	63	22	13	12,0	301 020 006
7	14,2	7,3	114	70	22	14	12,5	301 020 007
8	16,0	8,3	146	80	22	15	13,9	301 020 008
10	17,8	10,5	153	90	24	18	15,9	301 020 010

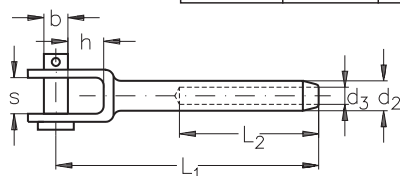

**ASS Mini-Terminaison à chape**

**ASS Jaw Terminal, Mini type**

DBGM

Ø câble rope-Ø mm	d <sub>2</sub> mm	d <sub>3</sub> mm	L <sub>1</sub> mm	L <sub>2</sub> mm	h mm	s mm	b mm	N° article stock no.
3	6,3	3,3	56	27	9	7	5	311 020 003
4	7,5	4,3	64	35	8	8	6	311 020 004
5	9,0	5,3	71	40	11	11	8	311 020 005
6	12,5	6,3	86	50	13	12	9	311 020 006

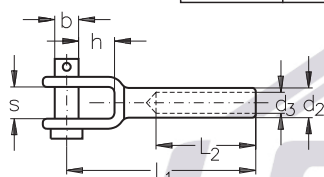

**ASS Super-Mini-Terminaison à chape**

**ASS Jaw Terminal, Super-Mini type**

DBP

Ø câble rope-Ø mm	d <sub>2</sub> mm	d <sub>3</sub> mm	L <sub>1</sub> mm	L <sub>2</sub> mm	h mm	s mm	b mm	N° article stock no.
3	5,5	3,5	45	20	9,5	7,5	5	321 020 003
4	6,3	4,4	45	22	9,5	7,5	5	321 020 004
5	7,5	5,3	52	25	10,0	10,0	6	321 020 005
6	9,0	6,5	58	30	11,0	11,0	8	321 020 006



**ASS Mini-Terminaison à tête fraisée**
**ASS Cone Terminal, Mini type**
**DBGM**

Ø câble rope-Ø mm	d <sub>1</sub> mm	d <sub>2</sub> mm	d <sub>3</sub> mm	L <sub>1</sub> mm	L <sub>2</sub> mm	h mm	N° article stock no.
3	8,0	6,3	3,3	34	27	2	311 030 003
4	9,5	7,5	4,3	43	35	2	311 030 004
5	13,0	9,0	5,3	50	40	3	311 030 005
6	16,5	12,5	6,3	64	50	3	311 030 006

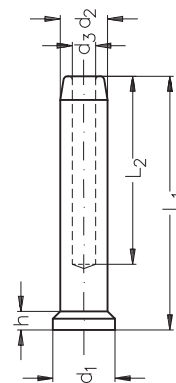
**ASS Super-Mini-Terminaison à tête fraisée**
**ASS Cone Terminal, Super-Mini type**
**DBP**

Ø câble rope-Ø mm	d <sub>1</sub> mm	d <sub>2</sub> mm	d <sub>3</sub> mm	L <sub>1</sub> mm	L <sub>2</sub> mm	h mm	N° article stock no.
2	7,6	4,5	2,2	21,0	15	1,7	321 030 002
3	8,7	5,4	3,3	27,0	20	2,0	321 030 003
4	10,9	6,5	4,3	29,0	22	2,5	321 030 004
5	12,5	7,5	5,3	32,5	25	3,0	321 030 005
6	15,0	9,0	6,3	38,0	30	4,0	321 030 006
8	20,0	12,5	8,5	50,0	40	5,0	321 030 008

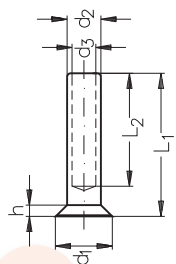
**ASS Super-Mini-Terminaison à tête bombée**
**ASS Dome head Terminal, Super-Mini type**
**DBP**

Ø câble rope-Ø mm	d <sub>1</sub> mm	d <sub>2</sub> mm	d <sub>3</sub> mm	L <sub>1</sub> mm	L <sub>2</sub> mm	h mm	N° article stock no.
2	7,6	4,5	2,2	19	15	1,65	321 040 002
3	8,7	5,4	3,3	25	20	1,70	321 040 003
4	10,9	6,5	4,3	27	22	2,20	321 040 004
5	12,5	7,5	5,3	30	25	2,50	321 040 005
6	15,0	9,0	6,3	35	30	3,00	321 040 006
8	20,0	12,5	8,5	48	40	4,00	321 040 008

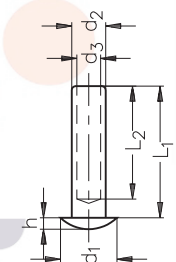
**S.A.**



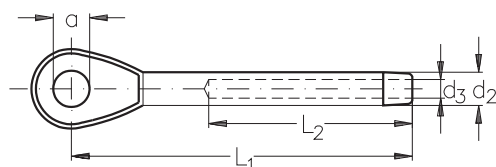

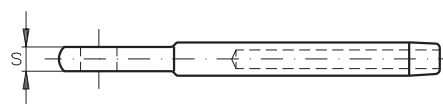

**Terminaison à œil INOX standard**

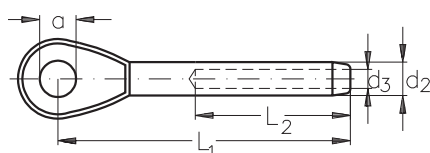

**NIRO Eye Terminal Standard type**

Ø câble rope-Ø mm	d <sub>2</sub> mm	d <sub>3</sub> mm	L <sub>1</sub> mm	L <sub>2</sub> mm	a mm	s mm	N° article stock no.
3	6,3	3,3	55	38	6,5	5,0	301 025 003
4	7,5	4,3	65	45	8,5	6,0	301 025 004
5	9,0	5,3	79	52	10,0	7,0	301 025 005
6	12,5	6,3	94	63	12,5	8,0	301 025 006
7	14,2	7,3	105	70	12,5	9,0	301 025 007
8	16,0	8,3	124	80	14,5	10,0	301 025 008
10	17,8	10,5	144	90	16,0	12,0	301 025 010



**ASS Mini-Terminaison à œil**

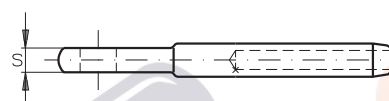

**ASS Eye Terminal, Mini type**

DBGM

Ø câble rope-Ø mm	d <sub>2</sub> mm	d <sub>3</sub> mm	L <sub>1</sub> mm	L <sub>2</sub> mm	a mm	s mm	N° article stock no.
3	6,3	3,3	40	18	6,5	5	311 025 003
4	7,5	4,3	52	24	8,5	6	311 025 004
5	9,0	5,3	62	30	9,5	7	311 025 005
6	12,5	6,3	75	36	13,0	8	311 025 006

**LEMMENS S.A.**

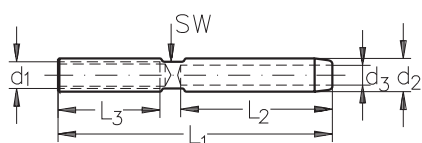

**ASS Mini-Terminaison taraudée**  
taraudée à droite ou à gauche

**ASS Threaded Terminal, Mini type**  
with internal thread, right and left hand

DBGM

Ø câble rope-Ø mm	Filetage thread d <sub>1</sub>	d <sub>2</sub> mm	d <sub>3</sub> mm	L <sub>1</sub> mm	L <sub>2</sub> mm	L <sub>3</sub> mm	SW mm	Filetage à droite right hand thread N° article stock no.	Filetage à gauche left hand thread N° article stock no.
3	M 5	6,5	3,3	54	27	20	5	311 012 003	311 013 003
4	M 6	7,5	4,3	62	35	20	6	311 012 004	311 013 004
5	M 6	9,0	5,3	67	40	20	7	311 012 005	311 013 005
6	M 8	12,5	6,3	82	50	25	10	311 012 006	311 013 006
8	M 10	16,0	8,3	106	60	40	14	311 012 008	311 013 008

Sans précision, les mini-terminaisons taraudées ci-dessus seront livrées filetées à droite.  
The ASS Threaded terminals, Mini type, with internal thread are delivered with right hand thread unless specified otherwise.

**Balustrades en câbles Inox**

Les balustrades sont des équipements de sécurité qui doivent protéger des chutes verticales. Les poteaux, mains courantes et hauteurs de balustrades sont calculés de telle façon à ce que personne ne puisse se blesser. La disposition des câbles doit rendre impossible le passage entre eux ainsi que l'enjambement d'un enfant.

**Ballustrading made from stainless steel ropes**

*Ballustrading is a security measure to protect falling. Posts, handrails and the height of the ballustrade should guarantee the safety of everyone. Infill ropes must ensure no one can fall through and infants can not over-climb them.*





### ASS Terminaison à vis

### ASS Screw terminal for self assembly

DBGM

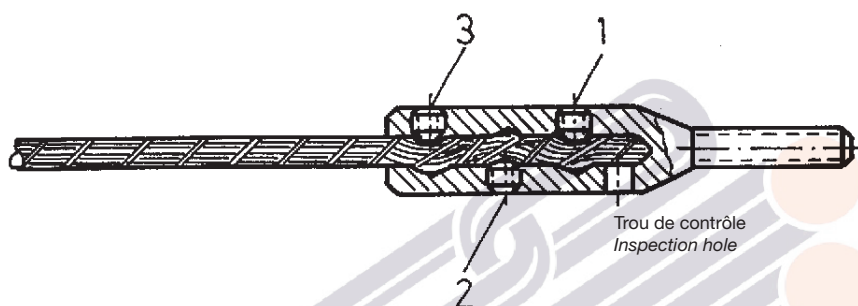

#### Note importante concernant les ASS terminaisons à vis montage manuel

Notre terminaison à vis, montage manuel est adaptée lorsque, sur un site extérieur la longueur des câbles n'a pu être déterminée avec précision.

Dans d'autres cas aussi, lorsque dans le domaine privé, par exemple, les câbles doivent être adaptés individuellement et les raccordements assemblés manuellement.

Dans tous ces cas, notre ASS Terminaison à vis, montage manuel, offre la meilleure solution pour les câbles de 2, 3 et 4 mm.

Les câbles ne doivent cependant pas être soumis à des charges trop importantes. Dans quelle mesure la tension du câble peut être sollicitée, dépend du soin apporté au montage. Il faut, en tous cas, minorer les charges en comparaison d'une terminaison sertie.

Pour le montage, le câble doit être poussé dans la terminaison jusqu'à ce qu'il apparaisse dans le trou de contrôle. Les vis seront serrées dans l'ordre 1, 2 et 3 (voir illustration). Grâce à cet assemblage, le câble, dans la terminaison, prendra la forme d'une courbe sinusoidale. Veillez à bien vérifier que l'extrémité du câble, après avoir serré les vis soit toujours visible dans le trou de contrôle.

#### Important notes for the ASS Self Assembly Screw terminal, Standard and Mini type

Our ASS Self Assembly Screw terminals are designed for fitting on-site when exact dimensions are not available in advance.

The ASS Self Assembly Screw terminals for wire ropes 2, 3 and 4 mm diameter are suitable for use by the non-professional but care must be taken with the fitting to the wire rope in order to achieve an acceptable capacity for the completed ropes.

Designed by our company and protected by DBGM the ASS Self Assembly Screw terminals are assembled on the rope by employing three threaded studs arranged in a radial direction at 180° to each other. By tightening the studs the rope is compressed and takes on the shape of a sinus curve inside the terminal.

Our break tests have indicated that the sinus curve gives a 50 % higher breaking load of the rope when compared to passing the rope through the fitting parallel. We employed a torque key and tightened the studs to 5 Nm for our tests and recommend the same procedure is used in the field.

The rope should be inserted into the terminal until it is visible through the inspection hole and studs should be tightened in order 1, 2, 3 as above instructions (see drawing).

The efficiency rating of these self assembly screw terminals is not as high as swaged or pressed terminals and therefore the total capacity of the rope must be reduced to cater for this.

**ASS Mini-Terminaison à vis à tige filetée droite ou gauche montage manuel**

**ASS Screw terminal, Mini type with outside thread, right and left hand for self assembly**

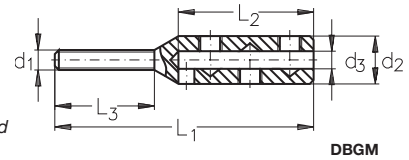

Désignation nominal size	Ø câble rope-Ø mm	Filetage thread d <sub>1</sub>	d <sub>2</sub> mm	d <sub>3</sub> mm	L <sub>1</sub> mm	L <sub>2</sub> mm	L <sub>3</sub> mm	Filetage à droite right hand thread N° article stock no.	Filetage à gauche left hand thread N° article stock no.
2	2	M 4	8	2,4	50	25	20	331 010 002	331 012 002
3	3	M 4	10	3,5	56	32	20	331 010 003	331 012 003
4	4	M 5	12	4,5	65	34	25	331 010 004	331 012 004

**Construction des câbles :**  
7 x 7 suivant DIN 3055  
7 x 19 suivant DIN 3060

**Rope constructions:**  
7 x 7 according to DIN 3055  
7 x 19 according to DIN 3060

**ASS Mini-Terminaison à vis taraudée droite ou gauche montage manuel**

**ASS Screw terminal, Mini type with internal thread, right and left hand for self assembly**

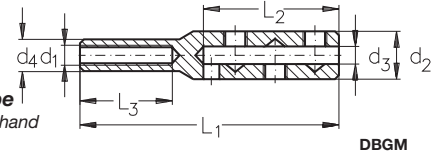

Désignation nominal size	Ø câble rope-Ø mm	Filetage thread d <sub>1</sub>	d <sub>2</sub> mm	d <sub>3</sub> mm	d <sub>4</sub> mm	L <sub>1</sub> mm	L <sub>2</sub> mm	L <sub>3</sub> mm	Filetage à droite right hand thread N° article stock no.	Filetage à gauche left hand thread N° article stock no.
2	2	M 4	8	2,4	6	50	25	20	331 210 002	331 212 002
3	3	M 4	10	3,5	6	56	32	20	331 210 003	331 212 003
4	4	M 5	12	4,5	8	65	34	25	331 210 004	331 212 004

**Construction des câbles :**  
7 x 7 suivant DIN 3055  
7 x 19 suivant DIN 3060

**Rope constructions:**  
7 x 7 according to DIN 3055  
7 x 19 according to DIN 3060

**ASS Mini-Terminaison à vis à œil, montage manuel**

**ASS Screw terminal, Mini type with eye for self assembly**

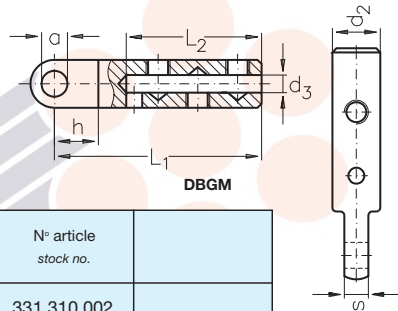

Désignation nominal size	Ø câble rope-Ø mm	d <sub>2</sub> mm	d <sub>3</sub> mm	L <sub>1</sub> mm	L <sub>2</sub> mm	a mm	s mm	h mm	N° article stock no.
2	2	8	2,4	37	25	4,5	4	9	331 310 002
3	3	10	3,5	43	32	5,5	5	11	331 310 003
4	4	12	4,5	52	34	6,5	6	11	331 310 004

**Construction des câbles :**  
7 x 7 suivant DIN 3055  
7 x 19 suivant DIN 3060

**Rope constructions:**  
7 x 7 according to DIN 3055  
7 x 19 according to DIN 3060

**ASS Mini-Terminaison à vis à chape, montage manuel**

**ASS Screw terminal, Mini type with jaw for self assembly**

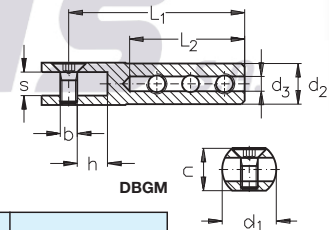

Désignation nominal size	Ø câble rope-Ø mm	c mm	d <sub>1</sub> mm	d <sub>2</sub> mm	d <sub>3</sub> mm	L <sub>1</sub> mm	L <sub>2</sub> mm	s mm	h mm	b	N° article stock no.
2	2	10,0	12	8	2,4	37	25	4,5	7	M 4	331 410 002
3	3	10,5	13	10	3,5	50	32	5,5	9	M 4	331 410 003
4	4	12,5	16	12	4,5	52	34	6,5	9	M 5	331 410 004

**Construction des câbles :**  
7 x 7 suivant DIN 3055  
7 x 19 suivant DIN 3060

**Rope constructions:**  
7 x 7 according to DIN 3055  
7 x 19 according to DIN 3060

**ASS Terminaison taraudée à droite montage manuel**

**ASS Screw terminal with right hand thread for self assembly**

Trou de contrôle inspection hole

DBGM

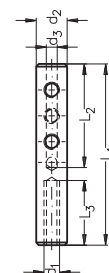

Désignation nominal size	Ø câble rope-Ø mm	d <sub>1</sub>	d <sub>2</sub> mm	d <sub>3</sub> mm	L <sub>1</sub> mm	L <sub>2</sub> mm	L <sub>3</sub> mm	N° article stock no.
4	3 + 4	M 6	12	4,5	70	40	25	331 510 004

**Construction des câbles :**  
7 x 7 suivant DIN 3055  
7 x 19 suivant DIN 3060

**Rope constructions:**  
7 x 7 according to DIN 3055  
7 x 19 according to DIN 3060



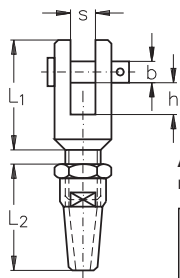

**ASS Terminaison à chape**  
montage manuel

**ASS Jaw terminal**  
for self assembly

Désignation nominal size	Ø câble rope-Ø mm	L <sub>1</sub> mm	L <sub>2</sub> mm	h mm	s mm	b mm	N° article stock no.
3	3	28	29	14	4,8	5	331 610 003
4	4	31	31	9	7	6	331 610 004
5	5	37	36	12	8	8	331 610 005
6	6	39	49	14	10	8	331 610 006
8	8	49	47	17	12	10	331 610 008
10	10	55	64	15	11	12	331 610 010
12	12	72	75	23	18	19	331 610 012

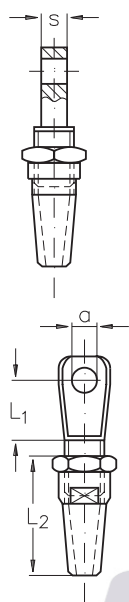

**ASS Terminaison à œil**  
montage manuel

**ASS Eye terminal**  
for self assembly

Désignation nominal size	Ø câble rope-Ø mm	L <sub>1</sub> mm	L <sub>2</sub> mm	a mm	s mm	N° article stock no.
3	3	21	29	5	5	331 620 003
4	4	22	31	6	6	331 620 004
5	5	36	36	8	8	331 620 005
6	6	36	50	11	9	331 620 006
8	8	27	47	15	11	331 620 008
10	10	40	64	16	11	331 620 010
12	12	44	75	19	19	331 620 012

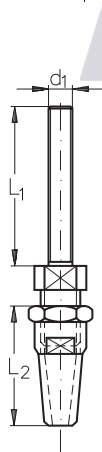

**ASS Terminaison à tige filetée**  
filetage à droite, montage manuel

**ASS Threaded Terminal with outside thread**  
for self assembly, right hand thread

Désignation nominal size	Ø câble rope-Ø mm	d <sub>1</sub>	L <sub>1</sub> mm	L <sub>2</sub> mm	N° article stock no.
3	3	M 6	40	29	331 710 003
4	4	M 8	50	31	331 710 004
5	5	M 10	66	36	331 710 005
6	6	M 12	72	49	331 710 006

n'existe pas avec filetage à gauche

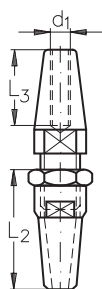

**ASS Terminaison conique taraudée à droite**  
montage manuel

**ASS Threaded Terminal with internal thread**  
for self assembly, right hand thread

Désignation nominal size	Ø câble rope-Ø mm	d <sub>1</sub>	L <sub>2</sub> mm	L <sub>3</sub> mm	N° article stock no.
3	3	M 5	29	15	331 720 003
4	4	M 6	31	15	331 720 004
5	5	M 8	36	20	331 720 005
6	6	M 8	49	20	331 720 006

n'existe pas avec taraudage à gauche

**Instructions d'assemblage pour ASS Terminaison à chape, à œil et à tige filetée ou taraudée.**  
**Assembly instructions for ASS Jaw terminal, ASS Eye terminal and ASS Threaded terminal**



Dans un premier temps, il faut dévisser la terminaison à chape ou à œil, taraudée ou filetée.  
 A l'intérieur, se trouvent deux clavettes : la clavette est de couleur jaune pour les constructions de câble 7 x 7 et 7 x 19 la clavette est de couleur blanche pour les constructions de câble 1 x 19

L'extrémité du câble doit être glissée dans la partie conique. Séparez à l'aide d'un objet les fils extérieurs de façon à laisser apparaître la partie intérieure (voir illustration)

La clavette doit être positionnée à l'intérieur de la rainure et doit se terminer à environ 1 à 2 mm au-dessus de l'extrémité du cône.  
 Les câbles extérieurs doivent être vrillés autour de la clavette de façon régulière. Assembler et visser les deux parties à l'aide de deux clés.

**Assembly instructions for ASS Jaw terminal, ASS Eye terminal and ASS Threaded terminal**

First unscrew the jaw/eye/threaded terminal.

Inside you will find two cones, one coloured yellow for 7 x 7 and 7 x 19 construction ropes and one coloured white for 1 x 19 construction ropes. Slide the screwed end over the rope, then unlay the outer wires to expose the core. The cone should be fed over the core and the outer wires laid back over it (see drawing).  
 The core should be laid in the groove and should end about 1-2 mm higher than the top edge of the cone. Assembly of the fitting can now take place by screwing both halves firmly together using a vice or two spanners.

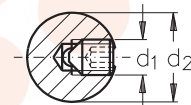
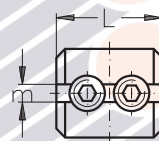

**ASS Manchon Serre-câble**

**ASS Cylindrical rope clip**

DBGM  
Design  
protégé  
registered  
design

Désignation nominal size	Ø câble rope-Ø mm	m mm	d <sub>1</sub>	d <sub>2</sub> mm	L mm	N° article stock no.
4	3 + 4	4,2	M 8	20	24	391 510 004
6	5 + 6	6,2	M 10	28	32	391 510 006

Utilisable que pour des constructions de câbles 7 x 7 et 7 x 19.  
 Only applicable for rope constructions 7 x 7 and 7 x 19.

**Pince coupante pour câble**

**Wire rope cutters**

Désignation nominal size	recommandé pour diamètre câble maxi recommended for ropes up to diameter mm	N° article stock no.
7	4	392 010 007
9	6	392 010 009





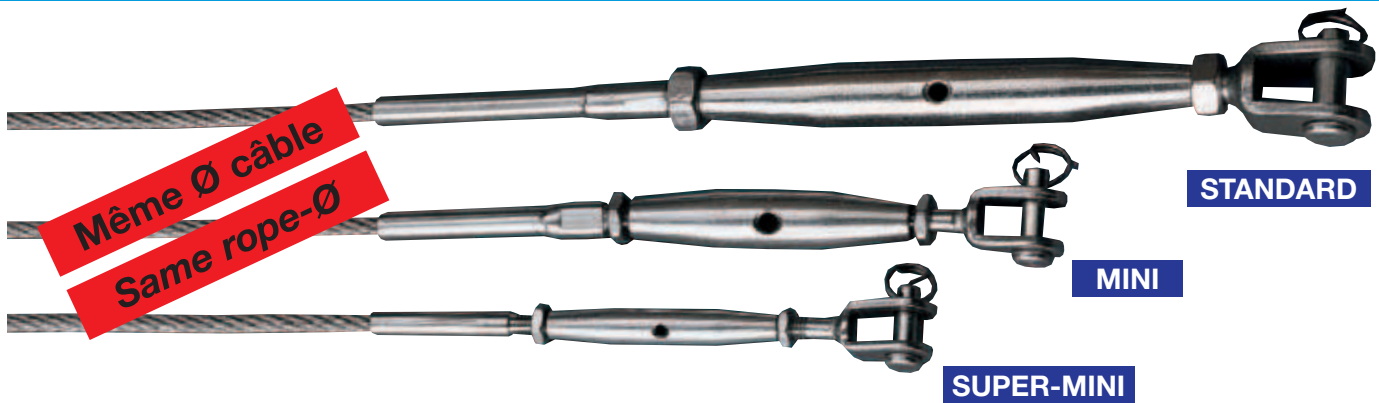

**UN** diamètre câble - **TROIS** générations de ridoirs  
**One** rope diameter - **Three** Rigging screw options

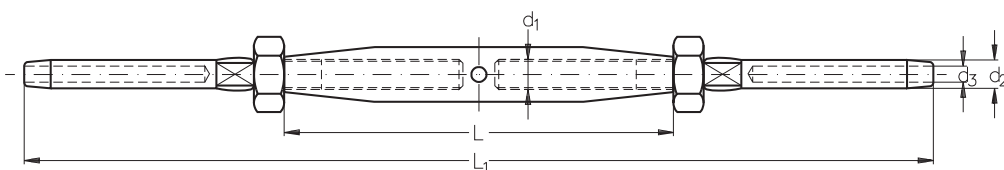

**Ridoir INOX**  
à deux terminaisons simples  
standard

**NIRO Rigging Screw**  
with terminal and terminal  
Standard type

Ø câble rope-Ø mm	Filetage thread d <sub>1</sub>	d <sub>2</sub> mm	d <sub>3</sub> mm	L mm	L <sub>1</sub> mm	N° article stock no.	
2,5	M 5	5,4	2,7	80	178	301 210 005	
3	M 6	6,3	3,3	95	203	301 210 006	
4	M 8	7,5	4,3	105	225	301 210 008	
5	M 10	9,0	5,3	125	260	301 210 010	
6	M 12	12,5	6,3	150	335	301 210 012	
8	M 16	16,0	8,3	190	440	301 210 016	
10	M 20	17,8	10,5	210	570	301 210 020	

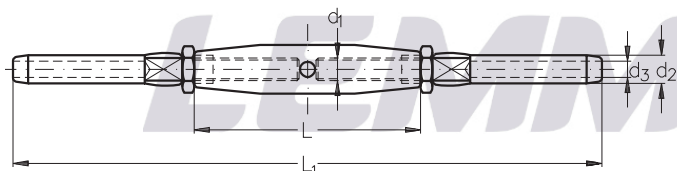

**ASS Mini-Ridoir**  
à deux terminaisons simples

**ASS Rigging Screw, Mini type**  
with terminal and terminal

DBGM design protégé  
registered design

Ø câble rope-Ø mm	Filetage thread d <sub>1</sub>	d <sub>2</sub> mm	d <sub>3</sub> mm	L mm	L <sub>1</sub> mm	N° article stock no.	
3	M 5	6,3	3,3	50	123	311 210 005	
4	M 6	7,5	4,3	60	158	311 210 006	
5	M 8	9,0	5,3	60	169	311 210 008	
6	M 10	12,5	6,3	80	220	311 210 010	

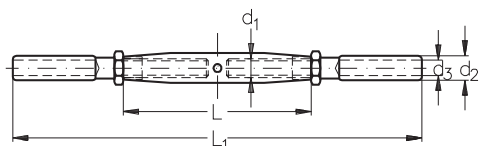

**ASS Super-Mini-Ridoir**  
à deux terminaisons simples

**ASS Rigging Screw, Super-Mini type**  
with terminal and terminal

DBGM design protégé  
registered design

Ø câble rope-Ø mm	Filetage thread d <sub>1</sub>	d <sub>2</sub> mm	d <sub>3</sub> mm	L mm	L <sub>1</sub> mm	N° article stock no.	
3	M 4	5,4	3,3	40	96	321 210 004	
4	M 5	6,5	4,3	50	110	321 210 005	
5	M 6	7,5	5,3	60	134	321 210 006	
6	M 8	9,0	6,3	60	142	321 210 008	

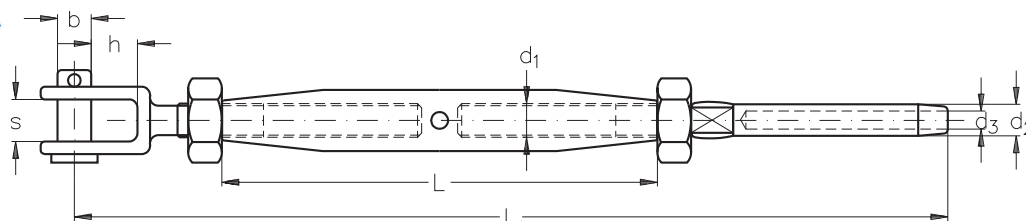

**Ridoir INOX**  
à chape fileté à gauche et terminaison à sertir standard

**NIRO Rigging Screw**  
with jaw and terminal  
Standard type

Ø câble rope-Ø mm	Filetage thread d <sub>1</sub>	d <sub>2</sub> mm	d <sub>3</sub> mm	h mm	s mm	b mm	L mm	L <sub>1</sub> mm	N° article stock no.
2,5	M 5	5,4	2,7	9	6	5,0	80	150	301 211 005
3	M 6	6,3	3,3	8,5	7	6,0	95	175	301 211 006
4	M 8	7,5	4,3	11	10	8,0	105	200	301 211 008
5	M 10	9,0	5,3	13	12	9,0	125	225	301 211 010
6	M 12	12,5	6,3	21	13	12,0	150	280	301 211 012
7	M 14	14,2	7,3	22	14	14,0	165	320	301 211 014
8	M 16	16,0	8,3	26	17	16,0	190	390	301 211 016
10	M 20	17,8	10,5	29	20	19,0	210	415	301 211 020

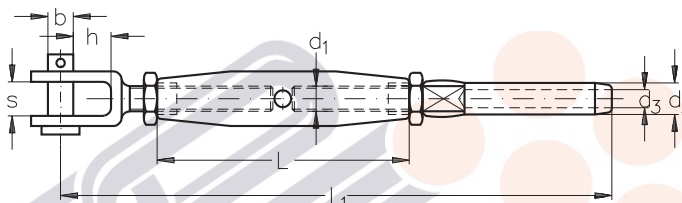

**ASS Mini-Ridoir**  
à chape fileté à gauche et terminaison simple

**ASS Rigging Screw, Mini type**  
with jaw and terminal

DBGM design protégé  
registered design

Ø câble rope-Ø mm	Filetage thread d <sub>1</sub>	d <sub>2</sub> mm	d <sub>3</sub> mm	h mm	s mm	b mm	L mm	L <sub>1</sub> mm	N° article stock no.
3	M 5	6,3	3,3	9	7	5	50	107	311 211 005
4	M 6	7,5	4,3	8	8	6	60	133	311 211 006
5	M 8	9,0	5,3	11	11	8	60	142	311 211 008
6	M 10	12,5	6,3	13	12	9	80	190	311 211 010

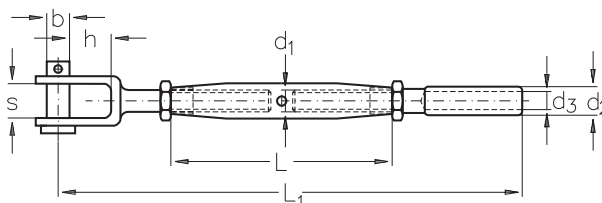

**ASS Super-Mini-Ridoir**  
à chape fileté à gauche et terminaison simple

**ASS Rigging Screw, Super-Mini type**  
with jaw and terminal

DBGM design protégé  
registered design

Ø câble rope-Ø mm	Filetage thread d <sub>1</sub>	d <sub>2</sub> mm	d <sub>3</sub> mm	h mm	s mm	b mm	L mm	L <sub>1</sub> mm	N° article stock no.
3	M 4	5,4	3,3	9	7	5	40	88	321 211 004
4	M 5	6,5	4,3	9	7	5	50	102	321 211 005
5	M 6	7,5	5,3	8	8	6	60	118	321 211 006
6	M 8	9,0	6,3	11	11	8	60	130	321 211 008





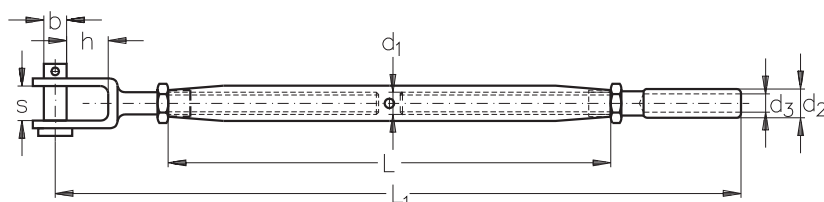

**ASS Super-Mini-Ridoir**  
à chape fileté à gauche et terminaison, **cage longue**

**ASS Rigging Screw, Super-Mini type**  
with jaw and terminal, **long type**

DBGM design protégé  
registered design

Ø câble rope-Ø mm	Filetage thread d <sub>1</sub>	d <sub>2</sub> mm	d <sub>3</sub> mm	h mm	s mm	b mm	L mm	L <sub>1</sub> mm	N° article stock no.
3	M 4	5,4	3,3	9	7	5	80	130	321 221 004
4	M 5	6,5	4,3	9	7	5	100	153	321 221 005
5	M 6	7,5	5,3	9	8	6	120	182	321 221 006
6	M 8	9,0	6,3	11	11	8	120	193	321 221 008

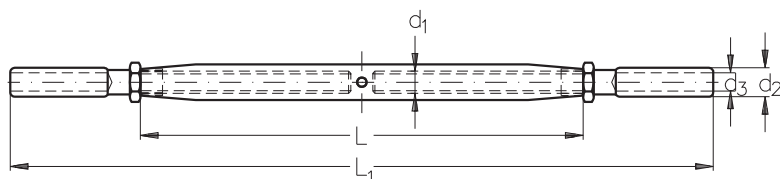

**ASS Super-Mini-Ridoir**  
à deux terminaisons, **cage longue**

**ASS Rigging Screw, Super-Mini type**  
with terminal and terminal, **long type**

DBGM design protégé  
registered design

Ø câble rope-Ø mm	Filetage thread d <sub>1</sub>	d <sub>2</sub> mm	d <sub>3</sub> mm	L mm	L <sub>1</sub> mm	N° article stock no.
3	M 4	5,4	3,3	80	135	321 220 004
4	M 5	6,5	4,3	100	160	321 220 005
5	M 6	7,5	5,3	120	193	321 220 006
6	M 8	9,0	6,3	120	204	321 220 008

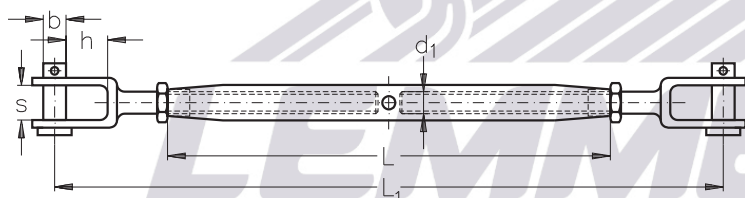

**ASS Super-Mini-Ridoir**  
à deux chapes, **cage longue**

**ASS Rigging Screw, Super-Mini type**  
with jaw and jaw, **long type**

Désignation nominal size	Filetage thread d <sub>1</sub>	h mm	s mm	b mm	L mm	L <sub>1</sub> mm	N° article stock no.
M 4	M 4	9	7	5	80	125	321 222 004
M 5	M 5	9	7	5	100	146	321 222 005
M 6	M 6	9	8	6	120	171	321 222 006
M 8	M 8	11	11	8	120	182	321 222 008

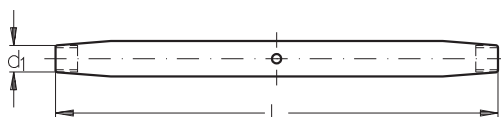

**ASS Super-Mini-Cage de ridoir**  
**cage longue**

**ASS Rigging Screw, Super-Mini type**  
**body only, long type**

Désignation nominal size	d <sub>1</sub>	L mm	N° article stock no.
M 4	M 4	80	321 223 004
M 5	M 5	100	321 223 005
M 6	M 6	120	321 223 006
M 8	M 8	120	321 223 008
M 10	M 10	160	321 223 010

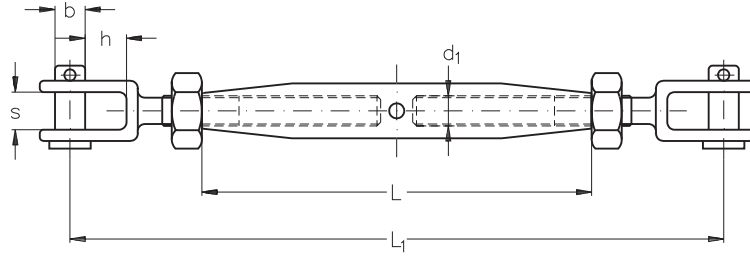

**Ridoir INOX**  
à deux chapes  
standard

**NIRO Rigging Screw**  
with jaw and jaw  
Standard type

Désignation nominal size	Filetage thread d <sub>1</sub>	h mm	s mm	b mm	L mm	L <sub>1</sub> mm	N° article stock no.
M 5	M 5	9	6	5,0	80	120	301 212 005
M 6	M 6	8,5	7	6,0	95	145	301 212 006
M 8	M 8	11	10	8,0	105	165	301 212 008
M 10	M 10	13	12	9,0	125	195	301 212 010
M 12	M 12	21	13	12,0	150	245	301 212 012
M 14	M 14	22	14	14,0	165	270	301 212 014
M 16	M 16	26	17	16,0	190	325	301 212 016
M 20	M 20	29	20	19,0	210	380	301 212 020

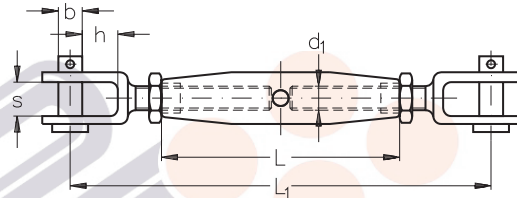

**ASS Mini-Ridoir**  
à deux chapes

**ASS Rigging Screw, Mini type**  
with jaw and jaw

Désignation nominal size	Filetage thread d <sub>1</sub>	h mm	s mm	b mm	L mm	L <sub>1</sub> mm	N° article stock no.
M 4	M 4	9	7	5	40	80	311 212 004
M 5	M 5	9	7	5	50	92	311 212 005
M 6	M 6	8	8	6	60	105	311 212 006
M 8	M 8	11	11	8	60	120	311 212 008
M 10	M 10	13	12	9	80	152	311 212 010

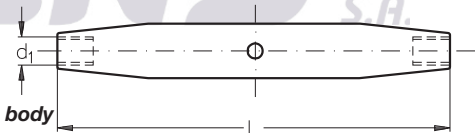

**Cage de Ridoir INOX**  
standard

**NIRO Rigging Screw - body**  
Standard type

Désignation nominal size	Filetage thread d <sub>1</sub>	L mm	N° article stock no.
M 5	M 5	80	301 213 005
M 6	M 6	95	301 213 006
M 8	M 8	105	301 213 008
M 10	M 10	125	301 213 010
M 12	M 12	150	301 213 012
M 16	M 16	190	301 213 016
M 20	M 20	210	301 213 020

**ASS Cage de Ridoir**  
pour Mini et Super-Mini

**ASS Rigging Screw - body**  
for Mini and Super-Mini type

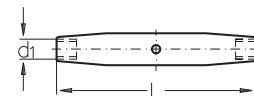

Désignation nominal size	Filetage thread d <sub>1</sub>	L mm	N° article stock no.
M 4	M 4	40	311 213 004
M 5	M 5	50	311 213 005
M 6	M 6	60	311 213 006
M 8	M 8	60	311 213 008
M 10	M 10	80	311 213 010



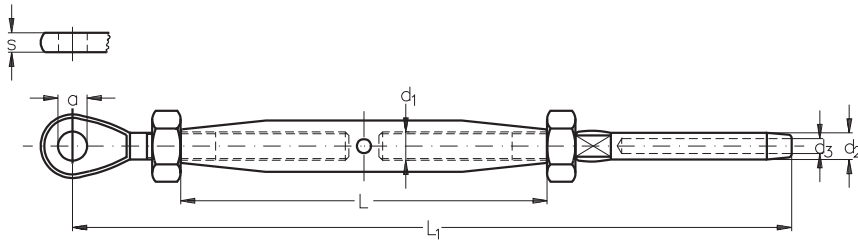

**Ridoir INOX**  
à œil et terminaison simple  
standard

**NIRO Rigging Screw**  
with eye and terminal  
Standard type

Ø câble rope-Ø mm	Filetage thread d <sub>1</sub>	d <sub>2</sub> mm	d <sub>3</sub> mm	a mm	s mm	L mm	L <sub>1</sub> mm	N° article stock no.
2,5	M 5	5,4	2,7	5,5	3	80	156	301 214 005
3	M 6	6,3	3,3	6,5	4	95	168	301 214 006
4	M 8	7,5	4,3	8,5	5	105	200	301 214 008
5	M 10	9,0	5,3	10,5	6	125	234	301 214 010
6	M 12	12,5	6,3	13,0	8	150	280	301 214 012
8	M 16	16,0	8,3	14,5	10	190	362	301 214 016
10	M 20	17,8	10,5	19,5	15	215	405	301 214 020

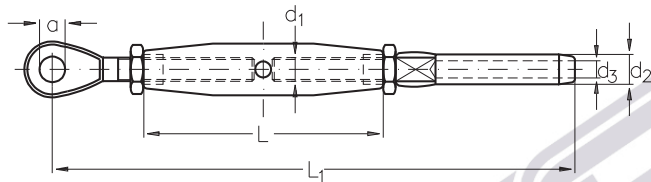
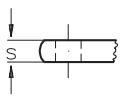

**ASS Mini-Ridoir**  
à œil et terminaison simple

**ASS Rigging Screw, Mini type**  
with eye and terminal

DBGM

Ø câble rope-Ø mm	Filetage thread d <sub>1</sub>	d <sub>2</sub> mm	d <sub>3</sub> mm	a mm	s mm	L mm	L <sub>1</sub> mm	N° article stock no.
3	M 5	6,3	3,3	5,5	3	50	111	311 214 005
4	M 6	7,5	4,3	6,5	4	60	130	311 214 006
5	M 8	9,0	5,3	8,5	5	60	139	311 214 008
6	M 10	12,5	6,3	10,5	6	80	181	311 214 010

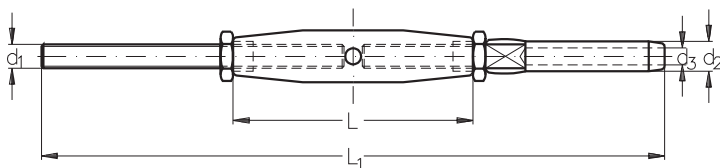

**ASS Mini-Ridoir**  
à tige filetée et terminaison simple

**ASS Rigging Screw, Mini type**  
with threaded rod and terminal

DBGM

Ø câble rope-Ø mm	Filetage thread d <sub>1</sub>	d <sub>2</sub> mm	d <sub>3</sub> mm	L mm	L <sub>1</sub> mm	N° article stock no.
3	M 5	6,3	3,3	50	124	311 217 005
4	M 6	7,5	4,3	60	152	311 217 006
5	M 8	9,0	5,3	60	168	311 217 008
6	M 10	12,5	6,3	80	215	311 217 010

Les ridoirs ci-dessus sont présentés avec une terminaison simple filetée à gauche, alors que la terminaison à œil ainsi que la tige filetée sont filetées à droite.

The above Rigging screws are assembled with left hand threaded terminals. The eye and rod end fittings are threaded right hand.

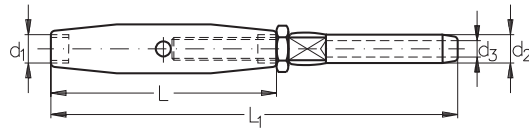

**ASS Mini-Ridoir**  
à terminaison simple (filetée à gauche)

**ASS Rigging Screw, Mini type**  
with one terminal (left hand thread)

DBGM

Désignation nominal size	Ø câble rope-Ø mm	Filetage thread d <sub>1</sub>	d <sub>2</sub> mm	d <sub>3</sub> mm	L mm	L <sub>1</sub> mm	N° article stock no.
M 5	3	M 5	6,3	3,3	50	86	311 215 005
M 6	4	M 6	7,5	4,3	60	109	311 215 006
M 8	5	M 8	9,0	5,3	60	115	311 215 008
M 10	6	M 10	12,5	6,3	80	150	311 215 010

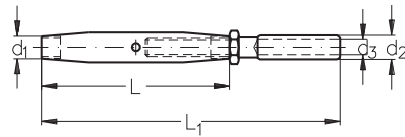

**ASS Super-Mini-Ridoir**  
à terminaison simple (filetée à gauche)

**ASS Rigging Screw, Super-Mini type**  
with one terminal (left hand thread)

DBGM

Désignation nominal size	Ø câble rope-Ø mm	Filetage thread d <sub>1</sub>	d <sub>2</sub> mm	d <sub>3</sub> mm	L mm	L <sub>1</sub> mm	N° article stock no.
M 4	3	M 4	5,4	3,3	40	68	321 215 004
M 5	4	M 5	6,5	4,3	50	80	321 215 005
M 6	5	M 6	7,5	5,3	60	97	321 215 006
M 8	6	M 8	9,0	6,3	60	102	321 215 008

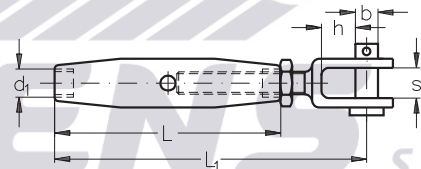

**ASS Mini-Ridoir**  
à chape (filetée à gauche)

**ASS Rigging Screw, Mini type**  
with one jaw (left hand thread)

Désignation nominal size	Filetage thread d <sub>1</sub>	h mm	s mm	b mm	L mm	L <sub>1</sub> mm	N° article stock no.
M 4	M 4	9	7	5	40	60	311 216 004
M 5	M 5	9	7	5	50	71	311 216 005
M 6	M 6	8	8	6	60	81	311 216 006
M 8	M 8	11	11	8	60	88	311 216 008
M 10	M 10	13	12	9	80	123	311 216 010

Les ridoirs ci-dessus sont présentés avec une terminaison simple filetée à gauche. L'autre extrémité est filetée à droite. Elle est libre de recevoir la terminaison de votre choix, telle que vis, tige filetée, etc.

The above Rigging screws are supplied with one terminal, other end is screwed right hand to facilitate the use of terminals of your choice i. e. threaded rods, screws etc.



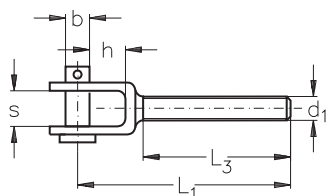

**ASS Mini-Tige filetée à chape**  
filetage à droite ou à gauche

**ASS Threaded Jaw, Mini type**  
with right and left hand thread

Désignation nominal size	Filetage thread d <sub>1</sub>	L <sub>1</sub> mm	L <sub>3</sub> mm	h mm	s mm	b mm	Filetage à droite right hand thread N° article stock no.	Filetage à gauche left hand thread N° article stock no.
M 4	M 4	40	20	9	7	5	311 520 004	311 521 004
M 5	M 5	45	25	9	7	5	311 520 005	311 521 005
M 6	M 6	52	30	8	8	6	311 520 006	311 521 006
M 8	M 8	57	30	11	11	8	311 520 008	311 521 008
M 10	M 10	77	40	13	12	9	311 520 010	311 521 010

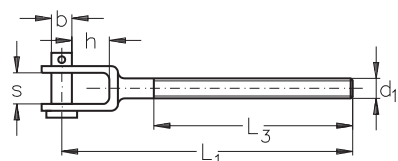

**ASS Super Mini-Tige filetée à chape, tige longue**  
filetage à droite ou à gauche

**ASS Threaded Jaw, Super-Mini type, long**  
with right and left hand thread

Désignation nominal size	Filetage thread d <sub>1</sub>	h mm	s mm	b mm	L <sub>1</sub> mm	L <sub>3</sub> mm	Filetage à droite right hand thread N° article stock no.	Filetage à gauche left hand thread N° article stock no.
M 4	M 4	9	7	5	60	40	321 520 004	321 521 004
M 5	M 5	9	7	5	70	50	321 520 005	321 521 005
M 6	M 6	9	8	6	82	60	321 520 006	321 521 006
M 8	M 8	11	11	8	87	60	321 520 008	321 521 008
M 10	M 10	13	12	9	105	78	321 520 010	321 521 010

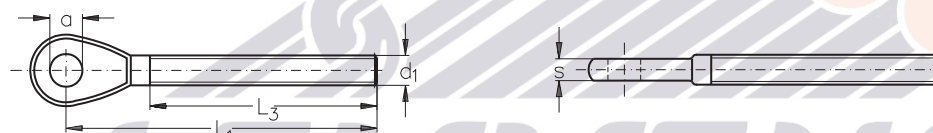

**Tige filetée à œil INOX, standard**  
filetage à droite

**NIRO Threaded Eye, Standard type**  
with right hand thread

Désignation nominal size d <sub>1</sub>	L <sub>1</sub> mm	L <sub>3</sub> mm	a mm	s mm	N° article stock no.
M 5	63	41	5,5	3	301 510 005
M 6	61	47	6,5	4	301 510 006
M 8	78	57	8,5	5	301 510 008
M 10	89	63	10,5	6	301 510 010
M 12	107	80	13,0	8	301 510 012
M 16	134	100	14,5	10	301 510 016
M 20	162	120	19,5	15	301 510 020



**ASS Mini-Tige filetée à œil**  
filetage à droite ou à gauche

**ASS Threaded Eye, Mini type**  
with right and left hand thread

Désignation nominal size d <sub>1</sub>	L <sub>1</sub> mm	L <sub>3</sub> mm	a mm	s mm	Filetage à droite right hand thread N° article stock no.	Filetage à gauche left hand thread N° article stock no.
M 5	47	25	5,5	3	311 510 005	311 511 005
M 6	48	30	6,5	4	311 510 006	311 511 006
M 8	56	35	8,5	5	311 510 008	311 511 008
M 10	66	40	10,5	6	311 510 010	311 511 010

Sans précision, les articles ci-dessus seront livrés filetés à droite.  
All items are delivered with right hand thread unless specified otherwise.

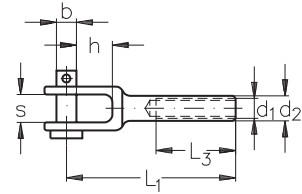

**ASS Mini-Chape taroudée**  
taroudée à droite ou à gauche

**ASS Jaw, Mini type**  
with **internal thread**, right and left hand

Désignation nominal size	d <sub>1</sub>	d <sub>2</sub> mm	h mm	s mm	b mm	L <sub>1</sub> mm	L <sub>3</sub> mm	Filetage à droite right hand thread N° article stock no.	Filetage à gauche left hand thread N° article stock no.
M 4	M 4	5,5	9,5	7,5	5	45	15	312 010 004	312 011 004
M 5	M 5	7,5	9,5	7,5	5	50	20	312 010 005	312 011 005
M 6	M 6	7,5	10,0	10,0	6	55	25	312 010 006	312 011 006
M 8	M 8	12,5	11,0	11,0	8	65	30	312 010 008	312 011 008

**ASS Chape à visser**

**ASS Plain Jaw**

Désignation nominal size	s mm	b mm	h mm	d mm	N° article stock no.
4	8,0	6	8	4,2	391 010 004
5	11,0	8	11	5,5	391 010 005
6	12,0	9	13	6,5	391 010 006
8	14,5	12	21	8,5	391 010 008

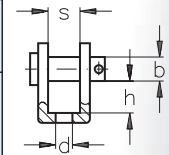

**ASS Chape à émerillon**  
filetage à droite

**ASS Swivel Jaw**  
with right hand thread

Désignation nominal size	d <sub>1</sub>	s mm	b mm	h mm	L mm	L <sub>3</sub> mm	N° article stock no.
M 4	M 4	8	6	8	34	20	391 011 004
M 5	M 5	11	8	11	43	25	391 011 005
M 6	M 6	12	9	13	53	30	391 011 006
M 8	M 8	14,5	12	21	67	35	391 011 008

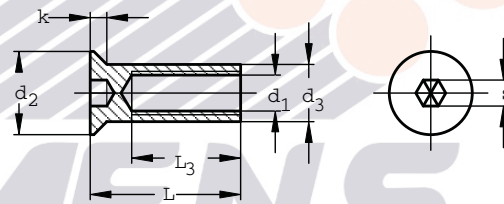
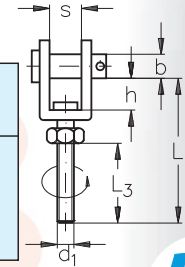

**ASS Douille de tension**  
taroudée à droite

Désignation d <sub>1</sub>	L mm	L <sub>3</sub> mm	k mm	d <sub>2</sub> mm	d <sub>3</sub> mm	s mm	N° article stock no.
M 3	15	10,5	2,0	9	5,0	3	367 010 003
M 4	15	10,5	2,0	9	5,5	3	367 010 004
M 5	29	21	2,0	10	6,6	3	367 010 005
M 6	29	21	2,7	12	8,0	4	367 010 006
M 8	29	21	3,2	16	11,0	5	367 010 008
M 10	30	21	3,7	20	14,0	6	367 010 010

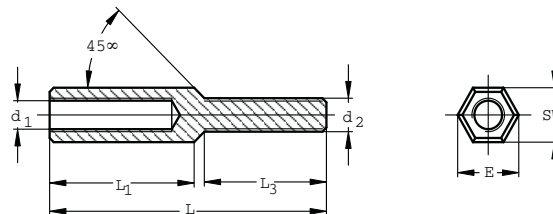

**ASS Manchon de tension**  
taroudé à gauche et fileté à droite

Designation d <sub>1</sub>	L mm	L <sub>1</sub> mm	L <sub>3</sub> mm	d <sub>1</sub> links	d <sub>2</sub> rechts	SW mm	E mm	N° article stock no.	EURO/pce EURO/pc
M 3	34	15	15	M 3	M 3	7	7,7	367 000 003	
M 4	45	20	20	M 4	M 4	7	7,7	367 000 004	
M 5	55	25	25	M 5	M 5	8	8,9	367 000 005	
M 6	65	30	30	M 6	M 6	10	11,1	367 000 006	
M 8	68	30	30	M 8	M 8	13	14,4	367 000 008	
M 10	90	40	40	M 10	M 10	17	18,9	367 000 010	



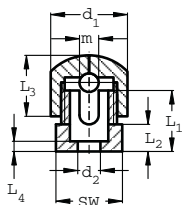

**ASS Serre-câble de fixation**  
pour câbles 3 mm, 4 mm et 5 mm

Désignation nominal size	L <sub>1</sub> mm	L <sub>2</sub> mm	L <sub>3</sub> mm	L <sub>4</sub> mm	d <sub>1</sub> mm	d <sub>2</sub> mm	SW mm	m mm	N° article stock no.
5	18	8	18	3	22	6,5	19	5,5	332 010 005

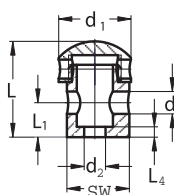

**ASS Serre-câble de fixation d'extrémité**  
adapté jusqu'au M 6

Désignation nominal size	L mm	L <sub>1</sub> mm	L <sub>4</sub> mm	d mm	d <sub>1</sub> mm	d <sub>2</sub> mm	SW mm	N° article stock no.
5	27	10	3	6,5	22	6,5	19	332 013 005

Avec les Serre-câbles de fixation d'extrémité, veuillez utiliser pour la fixation sur les terminaisons nos petits modèles de Boules ASS. Celles-ci s'appuieront sur la partie plate la plus étroite du serre-câble.

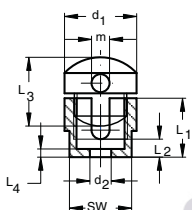

**ASS Serre-câble de fixation d'angle**  
pour câbles 3 mm, 4 mm et 5 mm

Désignation nominal size	L <sub>1</sub> mm	L <sub>2</sub> mm	L <sub>3</sub> mm	L <sub>4</sub> mm	d <sub>1</sub> mm	d <sub>2</sub> mm	SW mm	m mm	N° article stock no.
5	18	5,5	21	2,5	22	6,5	19	5,5	332 017 005

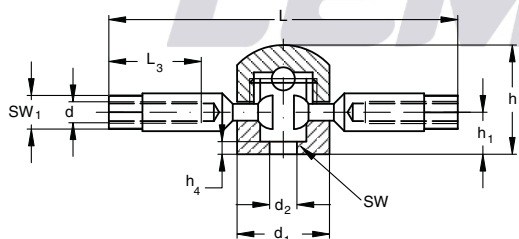

**ASS Serre-câble de fixation à rotule**

Désignation nominal size	L mm	L <sub>3</sub> mm	h mm	h <sub>1</sub> mm	h <sub>4</sub> mm	d droit	d <sub>1</sub> mm	d <sub>2</sub> mm	SW mm	SW <sub>1</sub> mm	N° article stock no.
M 5	81,5	22	26	10	3	M 5	22	6,5	19	8	332 110 005

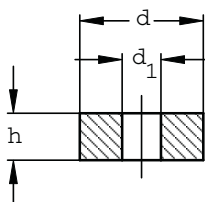

**Cale d'épaisseur pour ASS Serre-câble de fixation d'angle**

Désignation nominal size	d mm	d <sub>1</sub> mm	h mm	N° article stock no.	EURO/pce EURO/pc
6	21	6,6	6	332 101 006	
13	21	6,6	13	332 101 013	
25	21	6,6	25	332 101 025	





Montage avec ASS Serre-câble de fixation et Serre-câble de fixation d'extrémité



ASS Serre-câble de fixation



ASS Douille de tension montée



ASS Serre-câble de fixation d'angle



ASS Serre-câble de fixation d'extrémité



Tension du câble avec une ASS Douille de tension



Tension du câble à l'aide de ASS Manchon de tension



ASS Serre-câble à rotule



**ASS Positionneur d'angle multiple**  
 pour poteau plat

**ASS Angle positioner**  
 for flat posts

Désignation nominal size	pour filetage fits for thread	d mm	d <sub>1</sub> mm	d <sub>2</sub> mm	de from	w à to	de from mm	h à to mm	N° article stock no.	
6	M 4 - M 6	6,4	13	20	25°	45°	9,5	10,5	332 510 006	
10	M 8 - M 10	10,6	18	24	25°	45°	14,0	15,0	332 510 010	

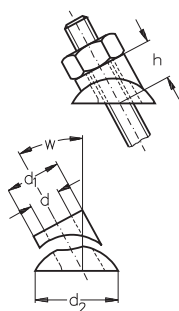

**ASS Positionneur d'angle multiple**  
 pour poteau rond

**ASS Angle positioner**  
 for round posts

DBP

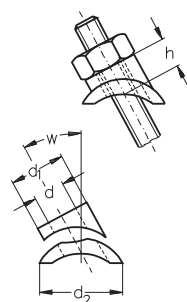
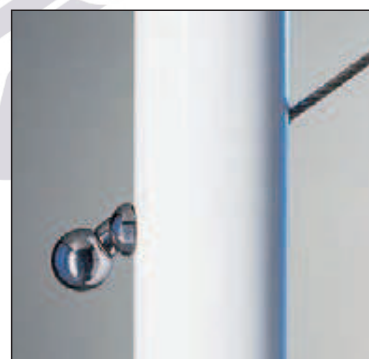
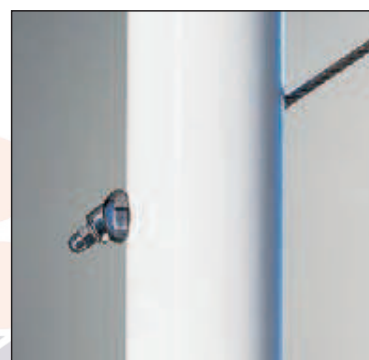
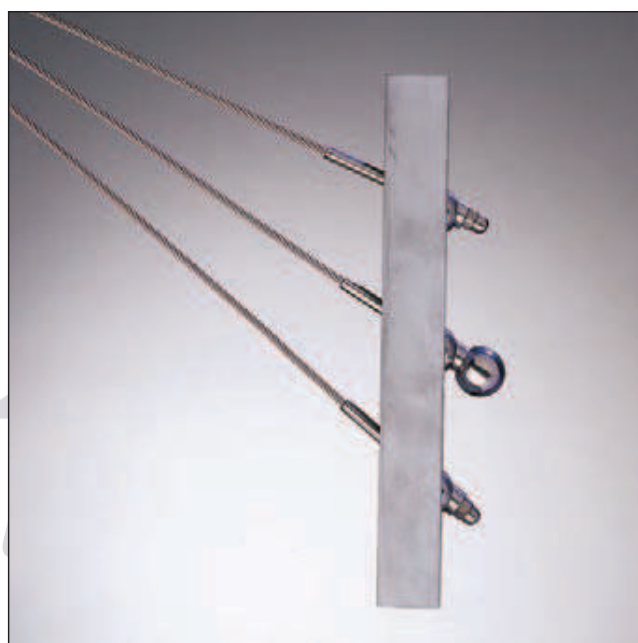
Désignation nominal size	pour filetage fits for thread	d mm	d <sub>1</sub> mm	d <sub>2</sub> mm	de from	w à to	de from mm	h à to mm	N° article stock no.	
6	M 4 - M 6	6,4	13	20	25°	45°	12	13	332 511 006	
10	M 8 - M 10	10,6	18	24	25°	45°	16	18	332 511 010	

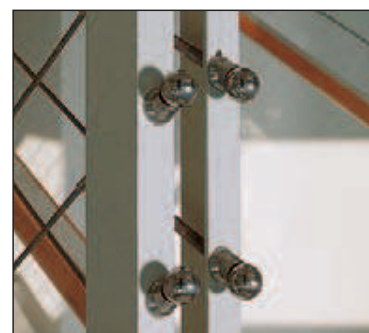
 Valables pour des poteaux d'un diamètre extérieur de 30 à 50 mm  
 For posts with an outside diameter of 30 - 50 mm.

 Le positionneur d'angle  
 ASS permet des angles  
 de 25° à 45°.

 The ASS Angle Positioner  
 permits tensioning of the rope  
 between 25 and 45 degrees.

**ASS Arrêt multi-angles**  
pour poteau plat

**ASS Angle Stopper**  
for flat posts

DBP

Désignation nominal size	Ø câble fits for rope mm	d mm	d <sub>1</sub> mm	d <sub>2</sub> mm	m mm	w		N° article stock no.
						de from	à to	
4	3 + 4	6,5	15	20	4,2	25°	45°	332 520 004
6	5 + 6	10,5	20	24	6,2	25°	45°	332 520 006

Utilisable uniquement avec des ASS Super-Mini-terminaisons et pour des constructions de câbles 7 x 7 et 7 x 19.

Only applicable with ASS Threaded terminals, Super-Mini type and for rope constructions 7 x 7 and 7 x 19.

Veuillez prendre en considération que la partie inférieure n'est pas fendue.

The bottom part is not slotted.

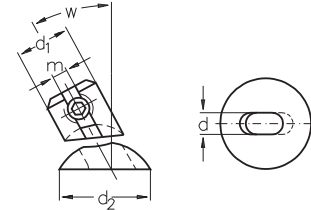

**ASS Arrêt multi-angles**  
pour poteau rond

**ASS Angle Stopper**  
for round posts

DBP

Désignation nominal size	Ø câble fits for rope mm	d mm	d <sub>1</sub> mm	d <sub>2</sub> mm	m mm	w		N° article stock no.
						de from	à to	
4	3 + 4	6,5	15	20	4,2	25°	45°	332 522 004
6	5 + 6	10,5	20	24	6,2	25°	45°	332 522 006

Utilisable uniquement avec des ASS Super-Mini-terminaisons et pour des constructions de câbles 7 x 7 et 7 x 19.

Only applicable with ASS Threaded terminals, Super-Mini type and for rope constructions 7 x 7 and 7 x 19.

Valables pour des poteaux d'un diamètre extérieur de 30 à 50 mm

For posts with an outside diameter of 30 - 50 mm.

Veuillez prendre en considération que la partie inférieure n'est pas fendue.

The bottom part is not slotted.

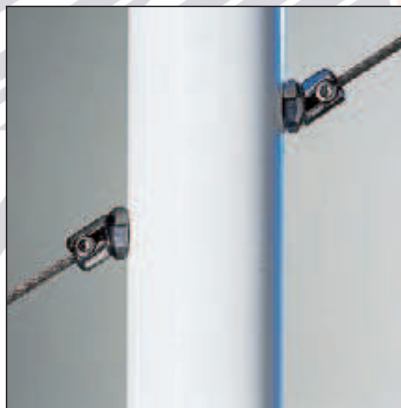
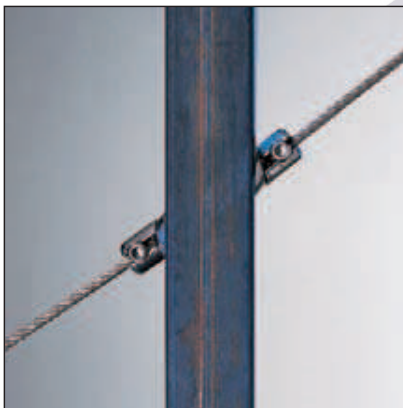
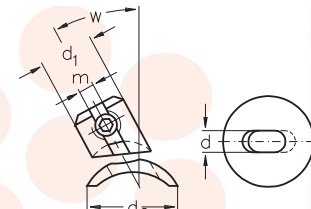

**ASS Rondelle spéciale**  
pour poteau rond

**ASS Special Washer**  
for round posts

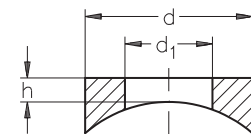

Désignation nominal size	pour filetage fits for thread up to	d mm	d <sub>1</sub> mm	h mm	Ø poteau diameter of the posts		N° article stock no.
					de from	à to	
6	M 6	13	6,6	3	30	50	333 010 006
10	M 10	21	11,0	3	30	50	333 010 010

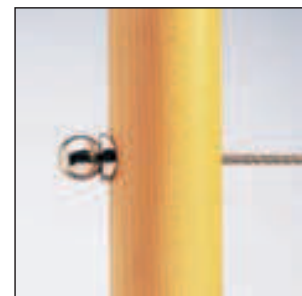
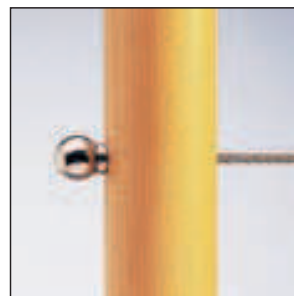
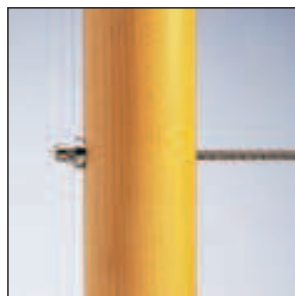

avec ASS Rondelle spéciale D. 6  
with ASS Special Washer NG 6

avec ASS Rondelle spéciale D. 6  
with ASS Special Washer NG 6

avec ASS Rondelle spéciale D. 10  
with ASS Special Washer NG 10



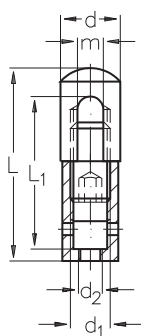

**ASS Suspension monobrin avec bague**

**ASS Hanging unit, simple type with attaching sleeve**

Désignation nominal size	∅ câble horizontal rope-∅ horizontal mm	∅ câble vertical Terminaison cylindrique rope-∅ vertical mm	∅ câble vertical Anneau de fixation rope-∅ vertical mm	L mm	L <sub>1</sub> mm	m mm	d mm	d <sub>1</sub>	d <sub>2</sub>	N° article stock no.
4	3 + 4	1,5 + 2	-	37,0	29	4,5	12	M 8	M 4	392 510 004
6	5 + 6	3 + 4	2	48,5	38	6,5	15	M 10	M 6	392 510 006

La tige filetée M 8 ou M 10 est incluse dans la livraison.

Stud M 8 or M 10 included.

**Applications**

Les ASS Suspensions monobrin et multibrins ont été conçues pour permettre à un câble tendu horizontalement de recevoir des suspensions verticales. Elles permettent l'accrochage de panneaux publicitaire, lampes, haut-parleurs etc. sans prise au plafond.

Avec ces mêmes pièces, il y a possibilité de stabiliser les câbles horizontaux de grandes longueurs par des fixations intermédiaires vers le haut.

**Applicability**

We have developed the ASS Hanging units to enable advertising boards, lights, loudspeakers etc. to be suspended from ceilings with the minimum of fixings. There are two types of ASS Hanging units the 'simple' and the 'multiple' both of which allow equipment to be hung vertically from a main horizontal rope.

In addition the ASS Hanging units may be used as a tensioning device or as an intermediate universal fitting on long horizontal rope runs.

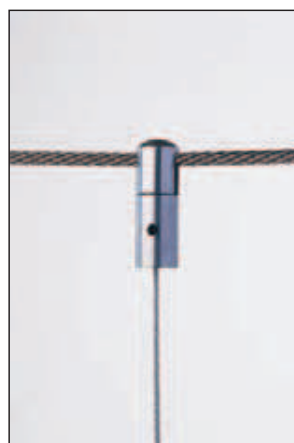
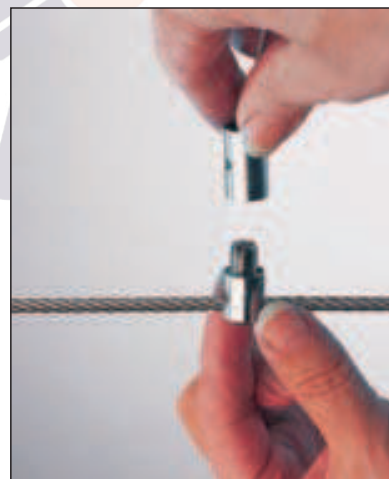

**ASS Suspension monobrins  
avec boulon à œil**

**ASS Hanging unit, simple type  
with eye bolt**

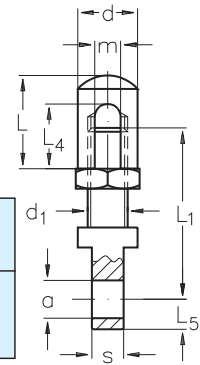

Désignation nominal size	Ø câble rope-Ø mm	L mm	L <sub>4</sub> mm	m mm	d mm	L <sub>1</sub> mm	d <sub>1</sub>	a mm	s mm	L <sub>5</sub> mm	N° article stock no.
4	3 + 4	17,0	12	4,5	12	35	M 8	6,5	6	6,0	392 520 004
6	5 + 6	23,5	16	6,5	15	43	M 10	9,5	8	7,5	392 520 006
10 *	8 + 10	34,5	25	10,5	25	-	M 16	-	-	-	392 520 010

\* dans cette désignation, seule la partie supérieure est disponible.

\* Top half available for this size only.

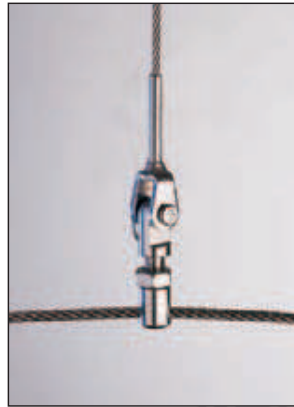

**ASS Suspension multibrins**

**ASS Hanging unit, multiple**

Désignation nominal size	Ø câble rope-Ø mm	L mm	L <sub>1</sub> mm	L <sub>2</sub> mm	h mm	h <sub>1</sub> mm	d mm	a mm	m mm	b mm	N° article stock no.
6	5 + 6	48	40	14	14	8	20	6,5	6,5	6	392 530 006



Vous trouverez de plus amples détails d'utilisations et d'applications sur notre ASS Console murale à la page 54.

Please find additional details regarding applicability and technical data for the ASS Wall bracket on page 54.

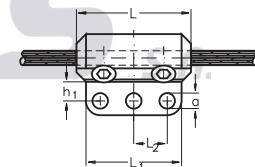
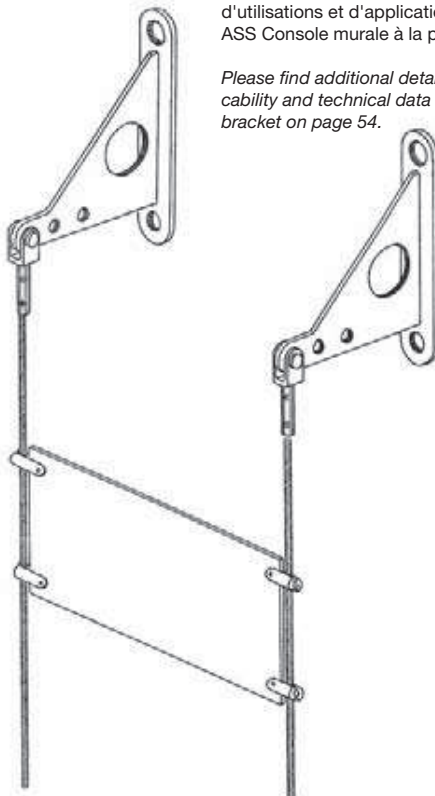

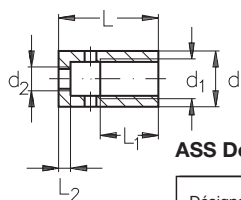

**ASS Douille à visser**
**ASS Attaching sleeve**

Désignation nominal size	*Ø câble Terminaison cylindrique rope-Ø mm	*Ø câble Anneau de fixation rope-Ø mm	L mm	L <sub>1</sub> mm	L <sub>2</sub> mm	d mm	d <sub>1</sub>	d <sub>2</sub>	N° article stock no.
M 8	1,5 + 2	-	20	12	3	12	M 8	M 4	351 010 008
M 10	3 + 4	2	25	15	3	14	M 10	M 6	351 010 010

\* Les câbles de suspension sont sertis avec une ASS Terminaison cylindrique. Le M 10 peut recevoir un câble de suspension de 2 mm avec un ASS Anneau de fixation.

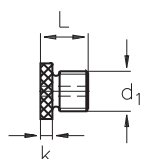
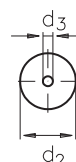
\* The rope must have an ASS Cylindrical Terminal swaged on one end. Size M 10 can be used on a 2 mm diameter wire rope using the ASS Clamping Ring.

**ASS Capuchon de douille**
**ASS Locking cap**

Désignation nominal size	L mm	k mm	d <sub>1</sub>	d <sub>2</sub> mm	d <sub>3</sub> mm	N° article stock no.
M 8	9	2,5	M 8	12	2,5	351 110 008
M 10	12	3,0	M 10	14	4,5	351 110 010



Montage avec ASS Terminaison cylindrique  
Assembly with ASS Cylindrical terminal



Montage avec ASS Anneau de fixation  
Assembly with ASS Clamping ring



pièces assemblées  
assembled

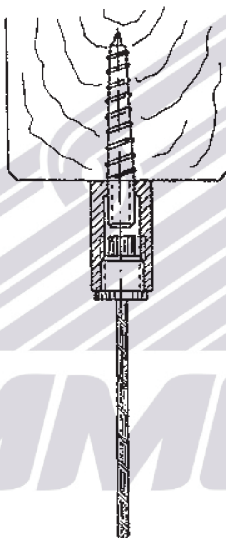

Fixation avec vis double filets bois/métaux.  
Suspension avec ASS Terminaison cylindrique.  
Fixing by wall stud  
Rope with ASS Cylindrical Terminal

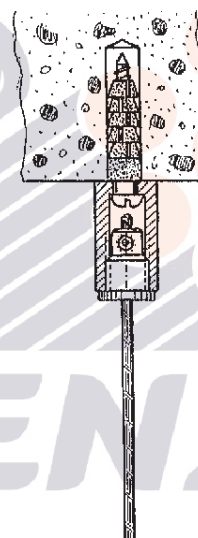

Fixation avec cheville.  
Suspension avec ASS Anneau de fixation.  
Fixing by dowel  
Rope with ASS Clamping Ring

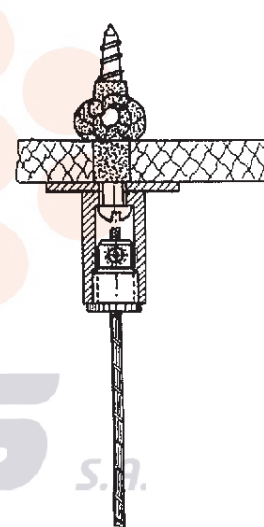

Fixation dans placoplâtre avec ASS Cache Inox.  
Fixing to plasterboard Panel with NIRO Cover Washer

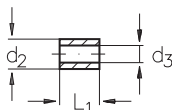
**ASS Terminaison cylindrique à sertir**
**ASS Cylindrical terminal**

Désignation nominal size	Ø câble rope-Ø mm	d <sub>2</sub> mm	d <sub>3</sub> mm	L <sub>1</sub> mm	N° article stock no.
2	2	5,4	2,2	6	351 210 002
3	3	6,3	3,3	8	351 210 003
4	4	7,5	4,3	10	351 210 004

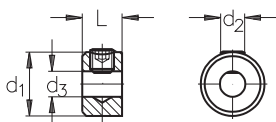
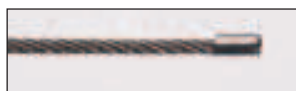
**ASS Anneau de fixation à visser**
**ASS Clamping ring**

Désignation nominal size	Ø câble rope-Ø mm	d <sub>1</sub> mm	d <sub>2</sub>	d <sub>3</sub> mm	L mm	N° article stock no.
2	2	8	M 4	2,3	6	351 310 002
3	3	10	M 4	3,3	6	351 310 003
4	4	12	M 4	4,3	8	351 310 004





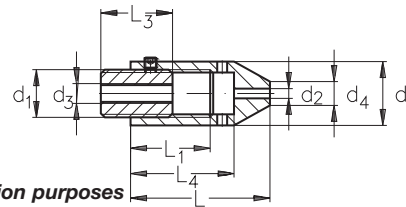

**ASS Déco-Douille de tension**

**ASS Tensioning unit for decoration purposes**

Désignation nominal size	Ø câble rope-Ø mm	L mm	L <sub>1</sub> mm	L <sub>3</sub> mm	L <sub>4</sub> mm	d mm	d <sub>1</sub>	d <sub>2</sub> mm	d <sub>3</sub>	d <sub>4</sub> mm	N° article stock no.	
2	1,5 + 2	35	20	18	26	16	M 12	2,5	M 5	6	351 410 002	
4	3 + 4	40	25	23	33	20	M 16	4,5	M 6	12	351 410 004	

à utiliser avec terminaison cylindrique ou anneau de fixation



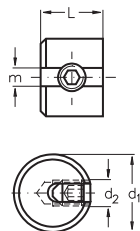

### ASS Arrêt-Butoir

### ASS Stopper

DBGM design protégé registered design

Désignation nominal size	Ø câble rope-Ø mm	m mm	d <sub>1</sub> mm	d <sub>2</sub>	L mm	N° article stock no.	
2	1,5 + 2	2,2	10	M 4	8	351 710 002	
4	3 + 4	4,3	15	M 8	12	351 710 004	
6	5 + 6	6,3	20	M 10	15	351 710 006	

Utilisable que pour des constructions de câbles  
7 x 7 et 7 x 19.

Only applicable for rope constructions 7 x 7 and 7 x 19.



Maniement facile



Easy Handling



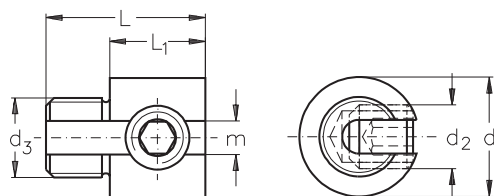

### ASS Arrêt d'extrémité

### ASS End stop

DBGM

Désignation nominal size	Ø câble rope-Ø mm	m mm	d <sub>1</sub> mm	d <sub>2</sub>	d <sub>3</sub>	L mm	L <sub>1</sub> mm	N° article stock no.
4	3 + 4	4,3	15	M 8	M 10	20	12	333 110 004

Utilisable que pour des constructions de câbles 7 x 7 et 7 x 19.

Only applicable for rope constructions 7 x 7 and 7 x 19.

L'arrêt d'extrémité ASS vous permet de positionner la longueur de chaque câble individuellement. L'extrémité du câble disparaît dans la boule ASS. Par conséquent, la finition est d'une part plus esthétique et d'autre part évite toute blessure par les torons du câble. L'arrêt d'extrémité est livré sans la boule ASS.

The ASS End stop enables you to cut the ropes according to your requirements. The wires at the end of the rope vanish into the screwed ASS Ball. On the one hand you have a pleasant end fitting, on the other hand the risk of injury by the sharp wires is averted. The ASS End stop is supplied without ASS Ball.

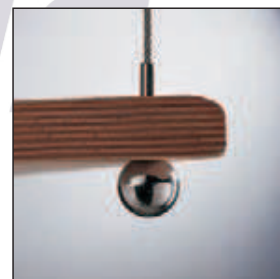
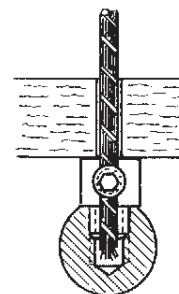

### ASS Boule tarudée à droite

### ASS Ball with internal thread, right hand

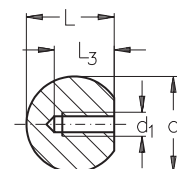

Désignation nominal size	Filetage thread d <sub>1</sub>	d <sub>2</sub> mm	L mm	L <sub>3</sub> mm	N° article stock no.
M 4/15	M 4	15	14,0	9	333 210 400
M 5/20	M 5	20	18,5	12	333 210 520
M 5/24	M 5	24	22,0	15	333 210 500
M 6/20	M 6	20	18,5	12	333 210 620
M 6/24	M 6	24	22,0	15	333 210 600
M 8/24	M 8	24	22,0	15	333 210 800
M 10/24	M 10	24	22,0	15	333 211 000



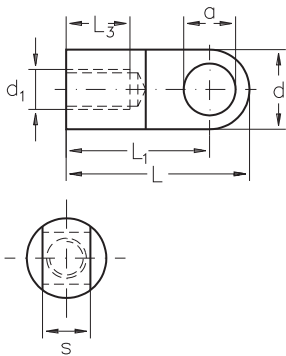

**ASS Œil taroué**  
taroué à droite

**ASS Wall/Ceiling Eyenut**  
with right hand thread

Désignation nominal size d <sub>1</sub>	d mm	L mm	L <sub>1</sub> mm	L <sub>3</sub> mm	a mm	s mm	N° article stock no.
M 4	10	23	18	5	5,5	6	351 810 004
M 5	10	23	18	5	6,5	6	351 810 005
M 6	14	30	23	6	8,5	7	351 810 006
M 8	16	33	25	8	9,5	9	351 810 008
M 10	18	34	25	12	9,5	7	351 810 010
M 12	20	36	25	15	9,5	7	351 810 012

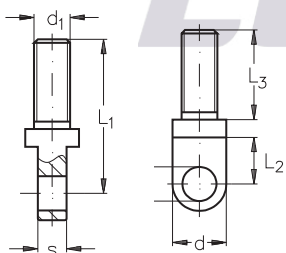
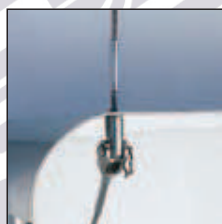

**ASS Œil fileté**

**ASS Eye bolt**

Désignation nominal size	L <sub>1</sub> mm	L <sub>2</sub> mm	L <sub>3</sub> mm	d mm	d <sub>1</sub>	a mm	s mm	N° article stock no.
M 8	35	11	20	12	M 8	6,5	6	351 910 008
M 10	43	13	25	15	M 10	9,5	8	351 910 010

© Waltermann France

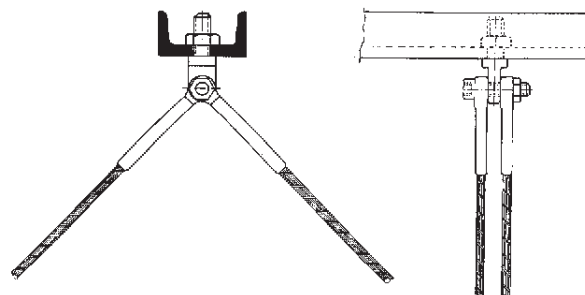
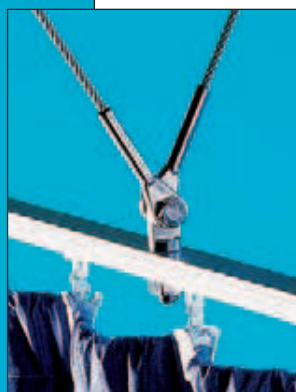
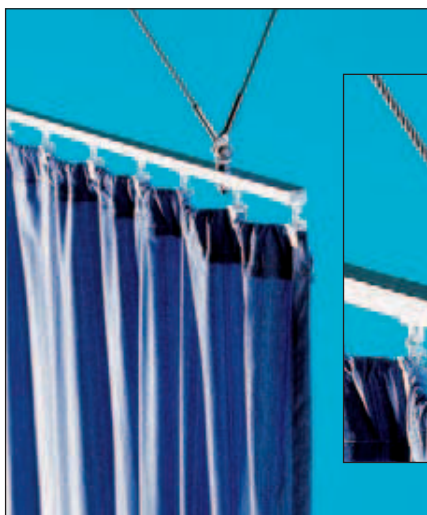



LE



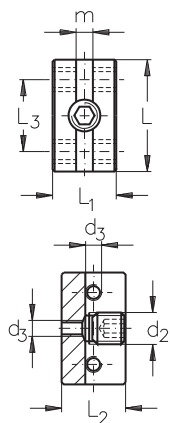

**ASS Support de rayonnage**
**ASS Shelf Support**

Désignation nominal size	Ø câble rope-Ø mm	m mm	L mm	L <sub>1</sub> mm	L <sub>2</sub> mm	L <sub>3</sub> mm	d <sub>2</sub>	d <sub>3</sub>	N° article stock no.
4	3 + 4	4,3	25	16	16	16	M 8	M 4	352 010 004

Utilisable que pour des constructions de câbles  
7 x 7 et 7 x 19.

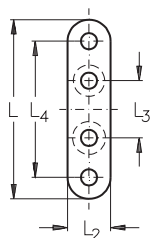
Only applicable for rope constructions 7 x 7 and 7 x 19.

**ASS Attache plate pour support de rayonnage Strap for ASS Shelf Support**

Désignation nominal size	L mm	L <sub>2</sub> mm	L <sub>3</sub> mm	L <sub>4</sub> mm	d <sub>1</sub> mm	d <sub>2</sub> mm	s mm	N° article stock no.
4	50	12	16	38	4,5	4,5	4	352 012 004

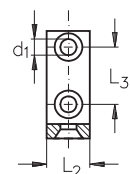
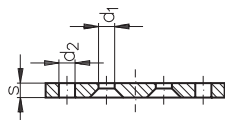
**ASS Attache cornière pour support de rayonnage Angle for ASS Shelf Support**

Désignation nominal size	L mm	L <sub>1</sub> mm	L <sub>2</sub> mm	L <sub>3</sub> mm	d <sub>1</sub> mm	s mm	N° article stock no.
4	30	30	12	16	4,5	4	352 013 004

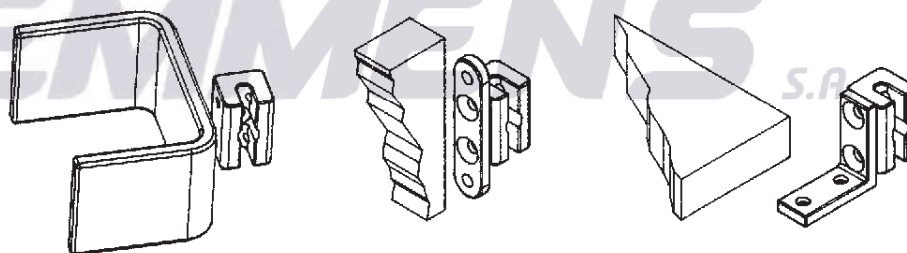
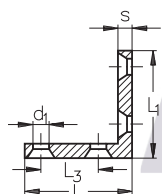

Le Support de rayonnage ASS peut, avec d'autres accessoires, être utilisé dans beaucoup de domaines.

The ASS Shelf Support can be used for numerous purposes as a single item or in connection with various accessories.

Ce Support de rayonnage ASS dispose d'une rainure pouvant recevoir un câble de 3 ou 4 mm de diamètre qui sera fixé à hauteur voulue par des vis sans tête. De chaque côté ainsi qu'à l'arrière du support se trouvent des trous taraudés M 4.

The ASS Shelf Support has a slot to accept a wire rope of 3 or 4 mm diameter. By the use of a stud the ASS Shelf Support can be fixed on the rope. On both sides you will find two threaded holes M 4. In addition there is another threaded hole M 4 on the rear.

Il existe donc la possibilité de fixer des rayonnages de chaque côté du support ou d'un côté seulement, ou encore en angle droit.

One has the ability to assemble e.g. shelf-units on both sides, single or at right angles directly with the ASS Shelf Support. By using two ASS Shelf Supports the shelf-units can be assembled at any angle. For the assembly of shelves, partitions or displays we supply accessories like angles or straps.

Nos ASS Attaches plates pour support de rayonnage ainsi que nos ASS Cornières d'attache pour support de rayonnage sont utilisées pour la fixation de rayonnage, de cloisons mobiles ou de support publicitaire.

For the construction of **closed partitions**, e.g. for use at fairs and exhibitions, one might use commercial clamping profiles. These profiles can be assembled directly to the ASS Shelf Support.



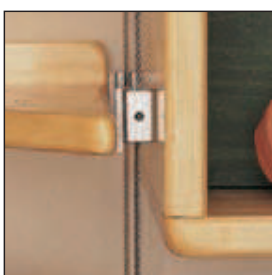
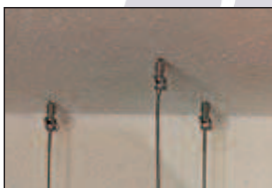
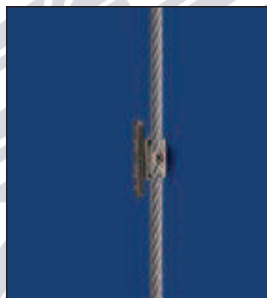
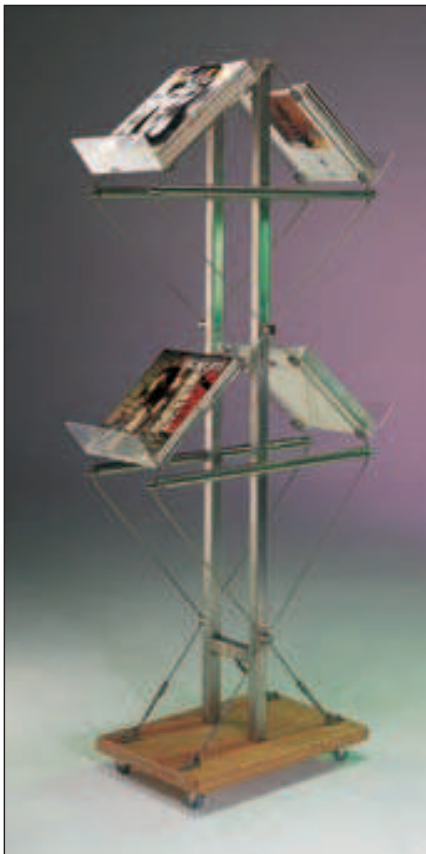

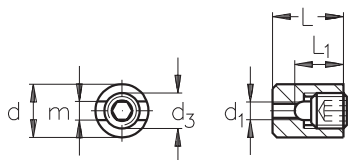

**ASS Display support**

**ASS Display clip**

Désignation nominal size	Ø câble rope-Ø mm	m mm	L mm	L <sub>1</sub> mm	d mm	d <sub>1</sub>	d <sub>3</sub>	N° article stock no.	
2	1,5 + 2	2,2	10	5	8	M 4	M 4	352 110 002	
4	3 + 4	4,2	16	11	12	M 4	M 8	352 110 004	
4/10	3 + 4	4,2	19	12	20	M 6	M 8	352 110 410	



LEMMENS S.A.



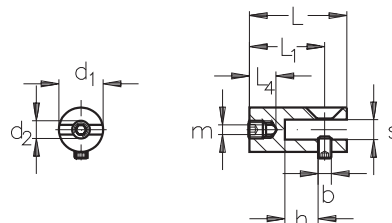

**ASS Support à chape**

**ASS Clamping jaw**

Désignation nominal size	Ø câble rope-Ø mm	L mm	L <sub>1</sub> mm	L <sub>4</sub> mm	d <sub>1</sub> mm	d <sub>2</sub>	m mm	h mm	b	s mm	N° article stock no.	
2	1,5 + 2	22	17	5	10	M 4	2,2	7,5	M 3	4,5	352 210 002	

En plus d'une vis M 4 x 4 pour la fixation de la chape, sont livrés une vis M 3 x 5 pour la fixation des panneaux et une vis à tête fraisée M 3 x 10 dans le cas d'un perçage dans le panneau.

The ASS Clamping Jaw is supplied with a M 4 x 4 stud for fixing the rope and a choice of M 3 x 5 stud or M 3 x 10 countersunk bolt for fixing the display material etc.

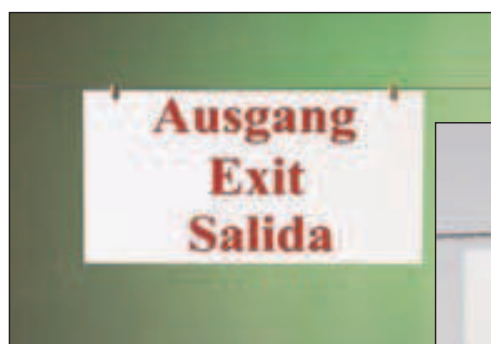

LEMME

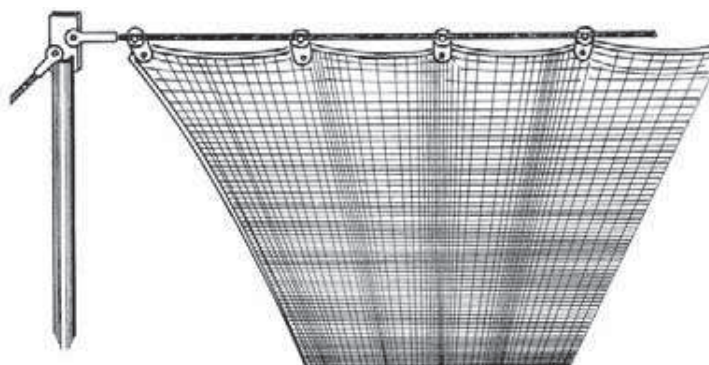

Exemple d'application d'un ASS Support à chape

Applicability ASS Clamping jaw  
Tensioning of textiles as protection against sun, view or for textile ceilings.



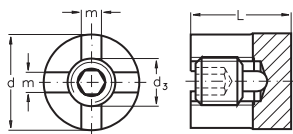

**Serre-câble croisé simple INOX**

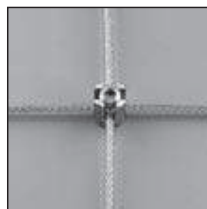

**NIRO Cross-over clip, simple**

Désignation nominal size	Ø câble rope-Ø mm	d mm	L mm	d <sub>3</sub>	m mm	N° article stock no.	
4	3 + 4	20	21	M 10	4,2	341 010 004	
6	5 + 6	20	25	M 12	6,2	341 010 006	

pour un croisement simple des câbles sous un angle de 90°

for simple rope cross-over at right angles

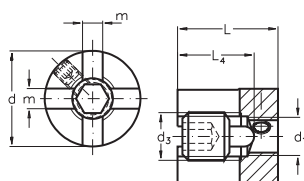

**Serre-câble croisé simple INOX avec fixation murale M 8**

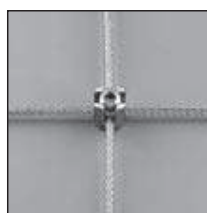

**NIRO Cross-over clip, simple with connection to the wall M 8**

Désignation nominal size	Ø câble rope-Ø mm	d mm	L mm	L <sub>4</sub> mm	d <sub>1</sub>	d <sub>3</sub>	m mm	N° article stock no.	
4	3 + 4	20	21	16	M 8	M 10	4,2	341 012 004	

pour un croisement simple des câbles sous un angle de 90°, et une fixation murale au moyen d'une tige filetée M 8 (non fournie)

for rope cross-over at right angles and wall fixing with M 8 threaded rod

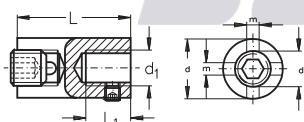

**ASS Serre-câble croisé 3 D avec fixation murale M 12**



**ASS Cross-over clip 3 D with connection to the wall M 12**

Désignation nominal size	Ø câble rope-Ø mm	d mm	L mm	d <sub>1</sub>	d <sub>3</sub>	L <sub>1</sub> mm	m mm	N° article stock no.	
4	3 + 4	20	36	M 12	M 10	10	4,2	341 014 004	
6	5 + 6	20	40	M 12	M 12	10	6,2	341 014 006	

pour un croisement des câbles sous un angle de 90°, et une fixation murale au moyen d'une tige filetée M 12 (non fournie). Trois différentes directions de câbles sont possibles (voir photo page 53)

for rope cross-over at right angles and wall fixing with M 12 threaded rod, three directional rope path possible (see photo page 53)

S.A.

DBGM



**ASS Serre-câble croisé multi-angles**

**ASS Cross-over clip**

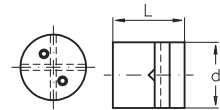

DBGM  
Design  
Protégé  
registered  
design

Désignation nominal size	Marquage marking	Ø câble rope-Ø mm	d mm	L mm	N° article stock no.
4	v	3 + 4	22	24	341 016 004
6	∨	5 + 6	22	26	341 016 006

pour un croisement des câbles sous n'importe quel angle

for rope cross-over at any angle

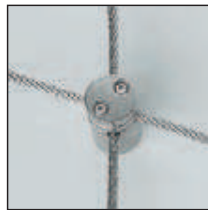

**ASS Serre-câble croisé multi-angles**  
avec fixation murale M 12

**ASS Cross-over clip**  
with connection to the wall M 12

DBGM  
design protégé  
registered design

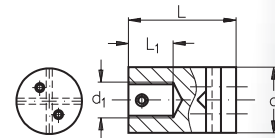

Désignation nominal size	Marquage marking	Ø câble rope-Ø mm	d <sub>1</sub>	d mm	L <sub>1</sub> mm	L mm	N° article stock no.
4	v	3 + 4	M 12	22	15	36	341 018 004
6	∨	5 + 6	M 12	22	15	38	341 018 006

pour un croisement des câbles sous n'importe quel angle, et une fixation murale au moyen d'une tige filetée M 12 (non fournie) (voir photo page 53)

for rope cross-over at any angle and wall fixing with M 12 threaded rod (see photo page 53)



**ASS Serre-câble croisé multi-angles**  
avec fixation murale M 12 et une déviation latérale à œil

**ASS Cross-over clip**  
with connection to the wall M 12 and eye connector

DBGM  
design protégé  
registered design

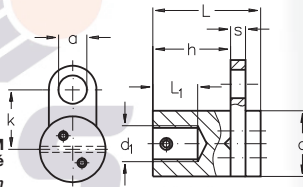

Désignation nominal size	Ø câble rope-Ø mm	d <sub>1</sub>	d mm	L <sub>1</sub> mm	L mm	s mm	k mm	h mm	a mm	N° article stock no.
6	3 - 6	M 12	22	15	36	6	20	24	9,5	341 020 006

pour un positionnement de câble horizontal et vertical, muni d'un œil latéral offrant une connexion supplémentaire et d'une fixation murale au moyen d'une tige filetée M 12 (non fournie) (voir photo page 53)

for ropes in the horizontal and vertical planes with one eye connector for additional connections, fixing to the wall with M 12 rod (see photo page 53)



**ASS Serre-câble croisé multi-angles**  
avec fixation murale M 12 et deux déviations latérales à œil

**ASS Cross-over clip**  
with connection to the wall M 12 and two eye connectors

DBGM  
design protégé  
registered design

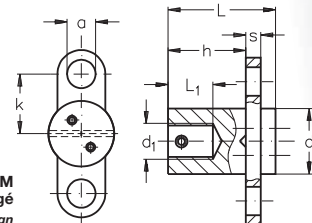

Désignation nominal size	Ø câble rope-Ø mm	d <sub>1</sub>	d mm	L <sub>1</sub> mm	L mm	s mm	k mm	h mm	a mm	N° article stock no.
6	3 - 6	M 12	22	15	36	6	20	24	9,5	341 021 006

pour un positionnement de câble horizontal et vertical, muni de deux œils latéraux offrant deux connexions supplémentaires et d'une fixation murale au moyen d'une tige filetée M 12 (non fournie)

for ropes in the horizontal and vertical planes with two eye connectors for additional connections, fixing to the wall with M 12 rod

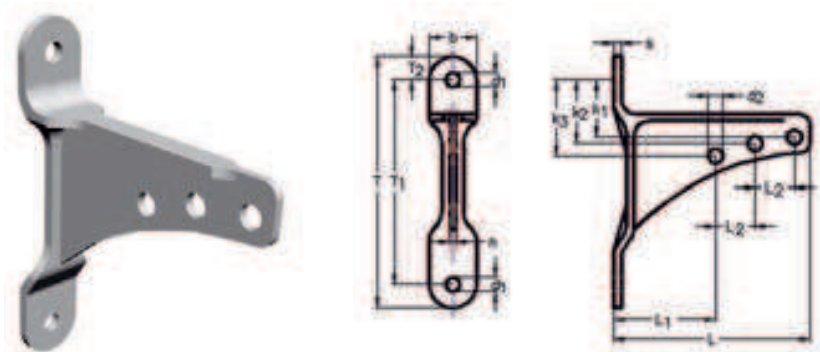

### ASS Console Murale

Fixation par terminaison à chape

### ASS Wall Bracket

for connection with jaws

T mm	T1 mm	T2 mm	d1 mm	d2 mm	s mm	b mm	n mm	L mm	L1 mm	L2 mm	k1 mm	k2 mm	k3 mm	N° article stock no.
160	130	15	9	9,5	5	30	4	125	65	25	36,5	40,5	48,5	341 520 005

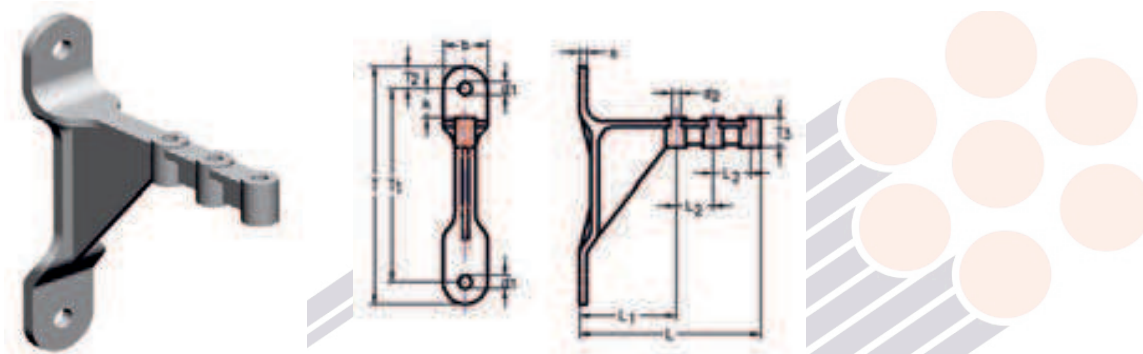

### ASS Console Murale

Fixation par terminaison filetée

### ASS Wall Bracket

for threaded terminal

T mm	T1 mm	T2 mm	T3 mm	k mm	d1 mm	d2 mm	s mm	b mm	L mm	L1 mm	L2 mm	N° article stock no.
160	130	15	20	20	9	6,2	5	30	122	65	25	341 520 001

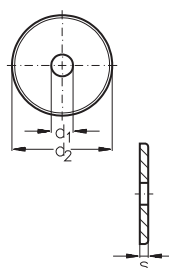

### ASS Rosace pour console murale

### ASS Rose for the wall bracket

Désignation nominal size	Présentation type	d1 mm	d2 mm	s mm	N° article stock no.
60 x 13	biseautée <i>turned with facet</i>	13	60	5	341 610 001
58 x 14	estampée <i>punched</i>	14	58	5	341 710 014

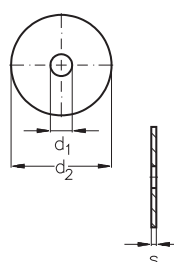

### Cache Inox pour console murale, estampé

### NIRO Cover Washer punched

Désignation nominal size	d2 mm	d1 mm	s mm	N° article stock no.
30	30	5,5	1,5	341 710 030
40	40	6,4	1,5	341 710 040
45	45	8,5	2,0	341 710 045
50	50	11,0	2,0	341 710 050
60	60	13,0	3,0	341 710 060
70	70	13,0	3,0	341 710 070



**ASS Console murale type Y**

**ASS Wall bracket, Y-type**

Désignation nominal size	d <sub>1</sub> mm	d <sub>2</sub> mm	d <sub>5</sub> mm	T <sub>1</sub> mm	L <sub>1</sub> mm	L <sub>2</sub> mm	a mm	b	s mm	N° article stock no.
70 x 13	13	70	30	26	22	11	4,0	M 6	8,5	341 810 070

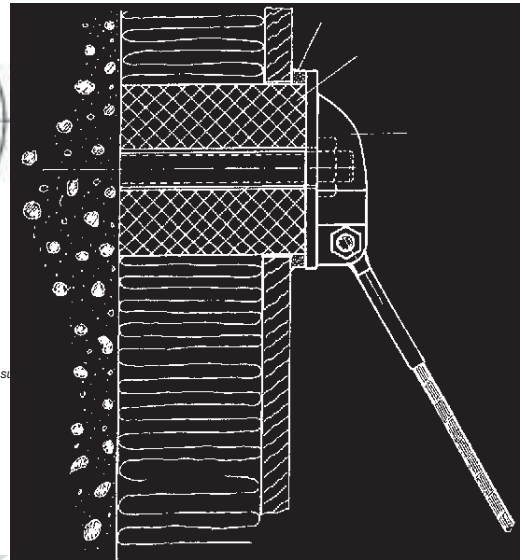
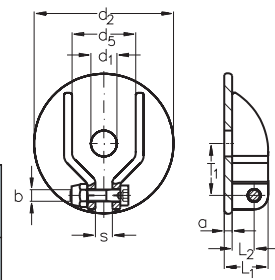

**ASS Console murale, petit modèle**

**ASS Wall bracket, small type**

Désignation nominal size	U mm	T mm	T <sub>1</sub> mm	s mm	L <sub>1</sub> mm	L <sub>2</sub> mm	d <sub>1</sub> mm	d <sub>2</sub> mm	N° article stock no.
10	10	28	16,5	2	14	7	6,5	5,5	341 910 010
20	20	48	30	3	20	9	8,5	6,5	341 910 020
30	30	70	45	4	30	16	12,5	9,5	341 910 030

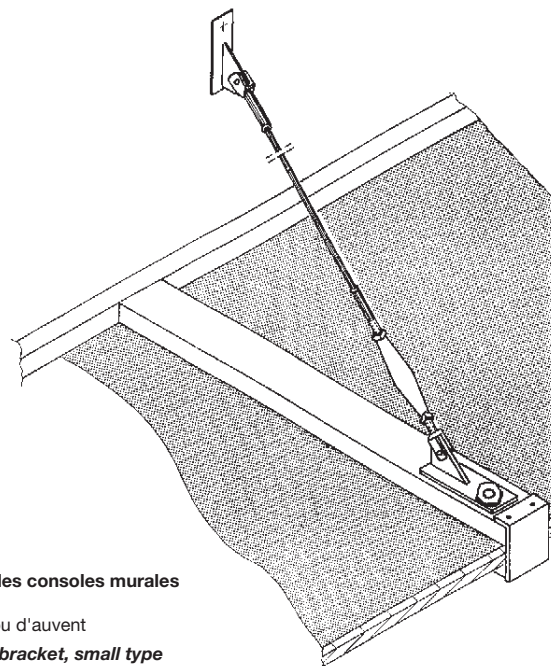
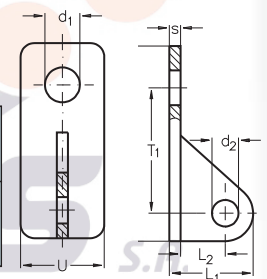

Exemple d'utilisation des consoles murales dés. 20 ou 30  
 Fixation de rayonnage ou d'auvent  
**Applicability ASS Wall bracket, small type**  
 Hanging of shelves or canopies



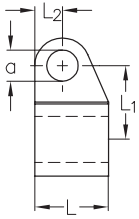

**ASS Douille à œil**

**ASS Sleeve with eye connector**

Désignation nominal size	L mm	L <sub>1</sub> mm	L <sub>2</sub> mm	d mm	d <sub>1</sub> mm	a mm	s mm	N° article stock no.
6	15	12	5	12	6,5	5,5	3	342 010 006
8	18	15	7,5	15	8,5	8,5	3	342 010 008
10	20	20	7,5	20	10,5	8,5	5	342 010 010
12	20	20	7,5	20	12,5	8,5	5	342 010 012

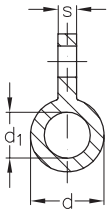

**Application  
Applicability**

Renfort horizontal pour treillage avec un grand écartement du mur et des plantes lourdes

*Horizontal running plant support with large distance to the wall and heavy plant forces of the vertical plant weight imparted*

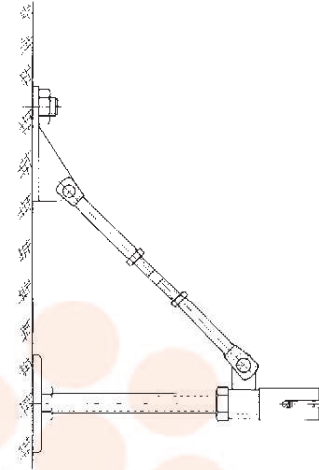
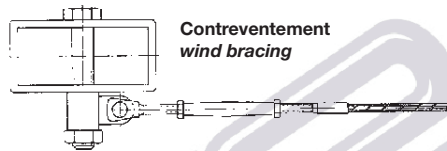

**ASS Élément de protection et de déviation**

**ASS Piggyback clip**

Désignation nominal size	Ø câble principal Ø main rope mm	Ø câble secondaire Ø cross rope mm	L mm	h mm	b mm	d mm	m mm	N° article stock no.
6	5 + 6	3 + 4	48	10	12	20	6,5	393 010 006



**Possibilité d'application**

Cette pièce sert à la déviation de câble secondaire par rapport à un câble principal, sans que ce dernier ne soit blessé par des angles aigus.

**Applicability**

*The ASS Piggyback Clip is meant for the stabilization of the rope. The rope will be tensioned at the point of intersection without sharp-edged bend in three-dimensional direction.*





Le support intermédiaire se compose de :

- Tige filetée M 12
- ASS Rosace ou Cache Inox
- Ecrou à six pans Inox
- ASS Serre-câble croisé

The distance unit consists of:

- NIRO Threaded rod M 12
- ASS Rose or NIRO Cover Washer
- NIRO Hexagon nut
- ASS Cross-over clip

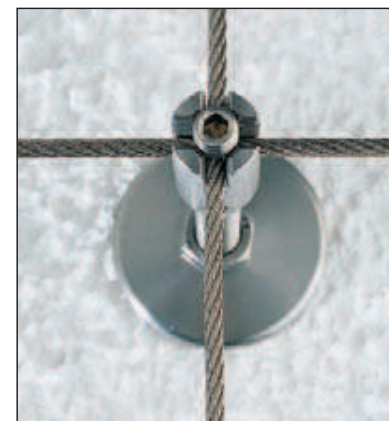





## **Conception et réalisation pour habiller un mur de verdure.**

Vous envisagez de faire pousser des plantes sur une façade ?

Afin de garantir un bon résultat, vous devez impérativement suivre les règles suivantes :

### Sélection des plantes

- L'exposition de la façade détermine le choix des plantes.
- La surface disponible (hauteur et largeur du mur) doit correspondre à la taille de la plante en pleine maturité.
- En outre la structure de la façade est décisive, si elle présente des joints ouverts ou des ouvertures de ventilation, il est déconseillé d'y faire pousser des plantes dont les pousses fuient la lumière car celles-ci y pénétreraient.

### Influence du vent

Lorsque vous avez sélectionné vos plantes, il faut prendre en considération le poids de celles-ci au stade de la maturité afin de déterminer la charge du vent sur l'ensemble de la construction.

### Construction et treillage

Les plantes ayant développé des techniques de pousse différentes (volubiles, sarmenteuses, à pousses, à crampons), les supports doivent toujours correspondre à ces techniques.

Le type de plante, son poids, la force du vent détermineront le nombre de câbles ainsi que le nombre de fixations intermédiaires.

Si le mur ne peut supporter les charges déterminées ci-dessus, il faudra augmenter le nombre de câbles et de points de fixation.

## **The planning and assembly of facade foliage**

Are you planning a facade with foliage?

To ensure a satisfactory result the following criteria must be considered.

### **Choice of plants**

- The aspect of the wall determines the choice of plants.
- The surface area available, allowing for final plant size.
- The facade construction, plants with vigorous tendrils will not be suitable if the wall has open joints.

### **Wind Effect**

The expected final weight of the selected plant must be considered when calculating the wind effect on the complete construction.

### **Construction and plant support**

Different type plants have evolved different climbing techniques, i.e. climbers, ramblers etc.

Plant type, wind force, weight and fixing of the anchoring system determine the number of ropes and intermediate fittings to be employed. If the wall or the facade cannot bear the calculated forces for structural reasons then more ropes and/or intermediate fittings must be used.



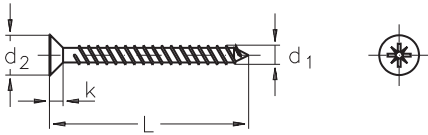

**Vis cruciforme INOX**  
pour bois aggloméré

**NIRO Cross recessed chipboard screw**

Désignation nominal size	d <sub>1</sub> mm	d <sub>2</sub> mm	L mm	k mm	N° article stock no.
3 x 25	3	6	25	1,9	303 010 325
4 x 40	4	8	40	2,5	303 010 440
5 x 50	5	10	50	3,0	303 010 550
6 x 60	6	12	60	3,6	303 010 660

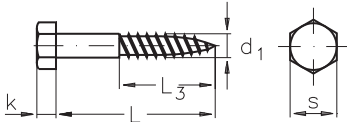

**Vis six pans à bois INOX, DIN 571**

**NIRO Hexagon wood screw acc. to DIN 571**

Désignation nominal size	d <sub>1</sub> mm	L mm	L <sub>3</sub> mm	s mm	k mm	N° article stock no.
5 x 30	5	30	18	8	3,5	303 011 530
6 x 40	6	40	24	10	4,0	303 011 640
6 x 70	6	70	42	10	4,0	303 011 670
8 x 80	8	80	48	13	5,5	303 011 880

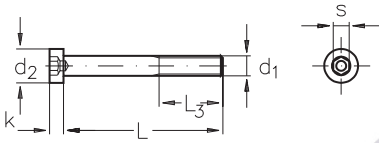

**Vis Allen tête basse INOX, DIN 6912**  
filetage à droite

**NIRO Cylindrical screw with hexagon  
socket head acc. to DIN 6912, right hand thread**

Désignation nominal size	d <sub>1</sub>	d <sub>2</sub> mm	L mm	L <sub>3</sub> mm	k mm	s mm	N° article stock no.
M 4 x 12	M 4	7,0	12	9,9	2,8	3	303 012 412
M 5 x 10	M 5	8,5	10	7,6	3,5	4	303 012 510
M 5 x 16	M 5	8,5	16	13,6	3,5	4	303 012 516
M 5 x 20	M 5	8,5	20	17,6	3,5	4	303 012 520
M 5 x 30	M 5	8,5	30	16,0	3,5	4	303 012 530
M 5 x 40	M 5	8,5	40	16,0	3,5	4	303 012 540
M 6 x 10	M 6	10	10	7,0	4,0	5	303 012 610
M 6 x 16	M 6	10	16	13,0	4,0	5	303 012 616
M 6 x 20	M 6	10	20	17,0	4,0	5	303 012 620
M 6 x 30	M 6	10	30	18,0	4,0	5	303 012 630
M 6 x 40	M 6	10	40	18,0	4,0	5	303 012 640
M 6 x 60	M 6	10,0	60	18,0	4,0	5	303 012 660
M 8 x 16	M 8	13,0	16	12,0	5,0	6	303 012 816
M 8 x 20	M 8	13,0	20	16,0	5,0	6	303 012 820
M 8 x 30	M 8	13,0	30	26,0	5,0	6	303 012 830
M 8 x 40	M 8	13,0	40	22,0	5,0	6	303 012 840
M 8 x 60	M 8	13,0	60	22,0	5,0	6	303 012 860

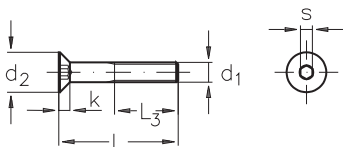

**Vis Allen tête fraisée INOX,  
DIN 7991**  
filetage à droite

**NIRO Countersunk bolt  
with hexagon socket head acc. to DIN 7991**  
right hand thread

Désignation nominal size	d <sub>1</sub>	d <sub>2</sub> mm	L mm	L <sub>3</sub> mm	k mm	s mm	N° article stock no.
M 4 x 10	M 4	8	10	-	2,3	2,5	303 013 410
M 4 x 25	M 4	8	25	14	2,3	2,5	303 013 425
M 5 x 30	M 5	10	30	16	2,8	3,0	303 013 530
M 6 x 50	M 6	12	50	18	3,3	4,0	303 013 650



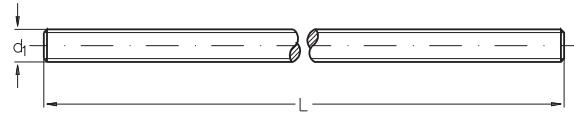

**Tige filetée INOX**  
filetage à droite

**NIRO Threaded rod**  
right hand thread

Désignation nominal size	d <sub>1</sub>	L mm	N° article stock no.
M 4	M 4	500	302 040 500
M 5	M 5	60	302 050 060
M 5	M 5	100	302 050 100
M 5	M 5	500	302 050 500
M 5	M 5	1000	302 051 000
M 6	M 6	70	302 060 070
M 6	M 6	110	302 060 110
M 6	M 6	500	302 060 500
M 6	M 6	1000	302 061 000
M 8	M 8	80	302 080 080
M 8	M 8	120	302 080 120
M 8	M 8	500	302 080 500
M 8	M 8	1000	302 081 000
M 10	M 10	100	302 100 100
M 10	M 10	500	302 100 500
M 10	M 10	1000	302 101 000
M 12	M 12	500	302 120 500
M 12	M 12	1000	302 121 000

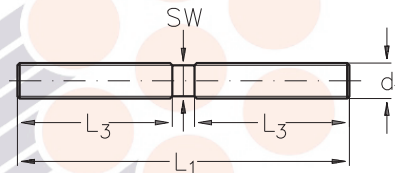

**Goujon INOX**  
une extrémité filetée à droite, l'autre à gauche

**NIRO Stud**  
right/left hand thread

Désignation nominal size d <sub>1</sub>	L <sub>1</sub> mm	L <sub>3</sub> mm	SW mm	N° article stock no.
M 5	55	25	4	302 510 005
M 6	65	30	5	302 510 006
M 8	75	35	7	302 510 008
M 10	85	40	9	302 510 010



**Vis à double filets INOX bois/métaux**  
Filetage bois toujours à droite  
filetage métrique à droite ou à gauche

**NIRO Wall Stud**  
with right and left hand thread

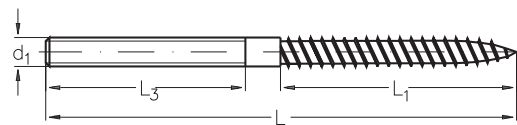

Désignation nominal size d <sub>1</sub>	L mm	L <sub>1</sub> mm	L <sub>3</sub> mm	Filetage à droite right hand thread N° article stock no.	Filetage à gauche left hand thread N° article stock no.
M 4 x 70	70	40	28	303 014 004	-
M 5 x 80	80	43	32	303 014 005	303 015 005
M 6 x 50	50	28	18	303 014 106	-
M 6 x 70	70	35	25	303 014 670	-
M 6 x 90	90	50	35	303 014 006	303 015 006
M 8 x 60	60	32	22	303 014 108	-
M 8 x 90	90	50	35	303 014 890	-
M 8 x 130	130	65	55	303 014 008	303 015 008
M 10 x 70	70	38	28	303 014 110	-
M 10 x 150	150	75	55	303 014 010	303 015 010
M 12 x 150	150	60	50	303 014 012	-

Sans précision, l'article ci-dessus sera livré fileté à droite.  
The Wall studs are delivered with right hand thread unless specified otherwise.

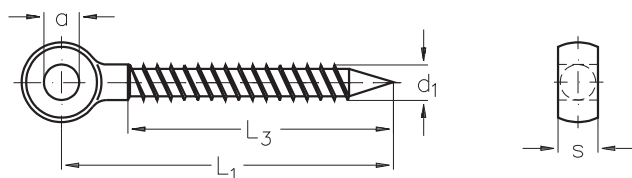

**Vis à œil INOX, DIN 444**  
filetage bois à droite

**NIRO Eye Bolt acc. to DIN 444**  
with wood thread, right hand

Désignation nominal size d <sub>1</sub>	L <sub>1</sub> mm	L <sub>3</sub> mm	a mm	s mm	N° article stock no.
5	60	50	5	6	303 016 005
6	60	50	6	7	303 016 006
8	75	60	8	9	303 016 008
10	85	70	10	12	303 016 010

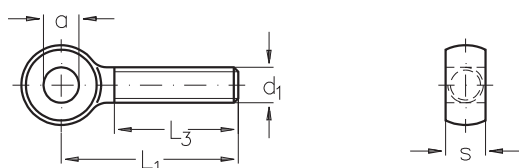

**Vis à œil INOX, DIN 444**  
filetage métrique à droite

**NIRO Eye Bolt acc. to DIN 444**  
with metric thread, right hand

Désignation nominal size d <sub>1</sub>	L <sub>1</sub> mm	L <sub>3</sub> mm	a mm	s mm	N° article stock no.
M 5	30	21	5	6	303 017 005
M 6	35	18	6	7	303 017 006
M 8	40	27	8	9	303 017 008
M 10	50	31	10	12	303 017 010



**Piton à œil fileté INOX**  
modèle long, filetage à droite

**NIRO Shank Collared Eye Bolt**  
long type, right hand thread

Désignation nominal size d <sub>1</sub>	L mm	L <sub>3</sub> mm	a mm	s mm	N° article stock no.
M 6	60	54	16	5	303 018 006
M 8	80	70	20	6	303 018 008
M 10	100	88	24	8	303 018 010
M 12	100	88	30	10	303 018 012

**Rondelle INOX, DIN 125**  
forme A

**NIRO Washer DIN 125**  
Form A

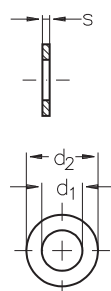

Désignation nominal size	d <sub>1</sub> mm	d <sub>2</sub> mm	s mm	N° article stock no.
4,3	4,3	9	0,8	303 110 004
5,3	5,3	10	1,0	303 110 005
6,4	6,4	12,5	1,6	303 110 006
8,4	8,4	17	1,6	303 110 008
10,5	10,5	21	2,0	303 110 010
13	13	24	2,5	303 110 013
17	17	30	3,0	303 110 017

**Ecrou borgne INOX, DIN 1587**  
filetage à droite

**NIRO Capped nut DIN 1587**  
right hand thread

Désignation nominal size	d	L mm	e mm	s mm	N° article stock no.
M 4	M 4	5	7,7	7	303 120 004
M 5	M 5	7,5	8,8	8	303 120 005
M 6	M 6	8	11,1	10	303 120 006
M 8	M 8	11	14,4	13	303 120 008
M 10	M 10	13	18,9	17	303 120 010
M 12	M 12	16	21,1	19	303 120 012
M 16	M 16	21	26,8	24	303 120 016

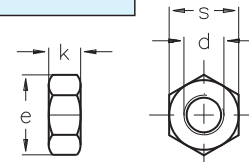
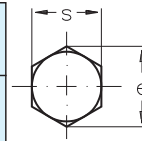
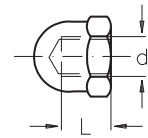

**Ecrou à six pans INOX, DIN 934**  
filetage à droite ou à gauche

**NIRO Hexagon nut DIN 934**  
right and left hand thread

Désignation nominal size	d	e mm	s mm	k mm	Filetage à droite right hand thread N° article stock no.	Filetage à gauche left hand thread N° article stock no.
M 3	M 3	6,0	5,5	2,4	303 510 003	303 511 003
M 4	M 4	7,7	7	3,2	303 510 004	-
M 5	M 5	8,8	8	4	303 510 005	303 511 005
M 6	M 6	11,1	10	5	303 510 006	303 511 006
M 8	M 8	14,4	13	6,5	303 510 008	303 511 008
M 10	M 10	18,9	17	8	303 510 010	303 511 010
M 12	M 12	21,1	19	10	303 510 012	303 511 012
M 16	M 16	26,8	24	13	303 510 016	303 511 016
M 20	M 20	33,6	30	19	303 510 020	303 511 020

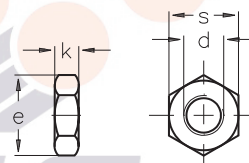

**Ecrou bas à six pans INOX, DIN 439**  
filetage à droite ou à gauche

**NIRO Hexagon lock nut DIN 439**  
right and left hand thread

Désignation nominal size	d	e mm	s mm	k mm	Filetage à droite right hand thread N° article stock no.	Filetage à gauche left hand thread N° article stock no.
M 4	M 4	7,7	7	2,1	303 512 004	303 513 004
M 5	M 5	8,8	8	2,7	303 512 005	303 513 005
M 6	M 6	11,1	10	3,2	303 512 006	303 513 006
M 8	M 8	14,4	13	4,0	303 512 008	303 513 008
M 10	M 10	18,9	17	5,0	303 512 010	303 513 010
M 12	M 12	21,1	19	6,0	303 512 012	303 513 012
M 16	M 16	26,8	24	8,0	303 512 016	303 513 016

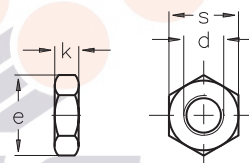

**Ecrou anti-desserrage INOX  
DIN 985**  
filetage à droite

**NIRO Self-locking hexagon nut  
acc. to DIN 985**  
right hand thread

Désignation nominal size	d	e mm	s mm	k mm	N° article stock no.
M 4	M 4	7,7	7	5	303 514 004
M 5	M 5	8,8	8	5	303 514 005
M 6	M 6	11,1	10	6	303 514 006
M 8	M 8	14,4	13	8	303 514 008
M 10	M 10	18,9	17	10	303 514 010
M 12	M 12	21,1	19	12	303 514 012

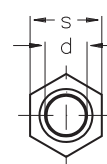
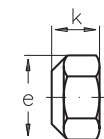

Sans précision, les articles ci-dessus seront livrés filetés à droite.  
All items are delivered with right hand thread unless specified otherwise.



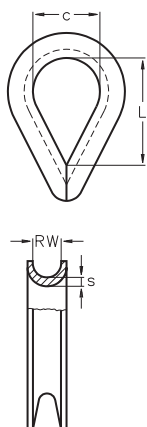

**Cosse INOX**
**NIRO Thimble**

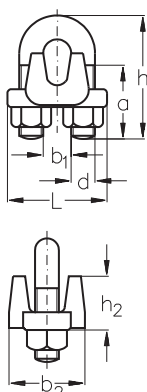
Gorge RW groove RW mm	c mm	L mm	s mm	N° article stock no.
3	10	18	1,0	308 900 003
4	11	20	1,0	308 900 004
5	13	21	1,0	308 900 005
6	16	28	1,2	308 900 006
7	17	31	1,2	308 900 007
8	19	33	1,4	308 900 008
10	24	38	1,9	308 900 010
12	27	42	2,0	308 900 012
14	33	51	2,2	308 900 014
16	37	60	2,5	308 900 016
18	41	67	4,0	308 900 018
20	46	73	4,0	308 900 020
22	49	78	5,0	308 900 022
24	55	93	5,0	308 900 024
28	67	105	6,0	308 900 028

**Serre-câble à étrier INOX**  
série lourde

**NIRO Wire rope clip**  
heavy pattern

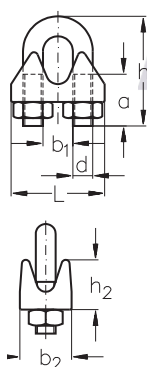
Désignation = Ø câble maxi nominal size = max. rope-Ø mm	a mm	b <sub>1</sub> mm	b <sub>2</sub> mm	d	h <sub>1</sub> mm	h <sub>2</sub> mm	L mm	N° article stock no.
2	10	4	15	M 3	17	10	14	309 000 002
3	12	5	15	M 3	21	12	16	309 000 003
4	13	6	18	M 4	23	13	18	309 000 004
5	14	7	21	M 5	27	16	20	309 000 005
6	18	8	23	M 6	32	18	27	309 000 006
8	22	10	28	M 8	41	20	34	309 000 008
10	27	12	36	M 10	51	23	44	309 000 010
12	33	14	38	M 12	62	27	50	309 000 012
14	38	15	44	M 12	69	31	52	309 000 014
16	45	18	47	M 14	79	35	59	309 000 016
18	47	20	52	M 14	81	38	61	309 000 018
22	61	25	61	M 18	103	45	77	309 000 022

**Serre-câble à étrier INOX**  
série légère

**NIRO Wire rope clip**  
light pattern

Désignation = Ø câble maxi nominal size = max. rope-Ø mm	a mm	b <sub>1</sub> mm	b <sub>2</sub> mm	d	h <sub>1</sub> mm	h <sub>2</sub> mm	L mm	N° article stock no.
2	10	4	10	M 3	18	10	18	309 010 002
3	12	5	10	M 3	22	11	19	309 010 003
4	12	6	11	M 4	23	13	22	309 010 004
5	15	7	13	M 5	28	15	26	309 010 005
6	18	8	16	M 6	33	17	29	309 010 006
8	18	11	18	M 6	36	20	32	309 010 008
10	22	13	20	M 8	45	23	38	309 010 010
13	26	15	26	M 10	55	25	47	309 010 013
16	32	18	27	M 10	65	32	53	309 010 016
19	36	22	29	M 12	75	38	62	309 010 019
22	38	24	31	M 12	83	43	63	309 010 022
25	45	27	31	M 14	94	43	68	309 010 025

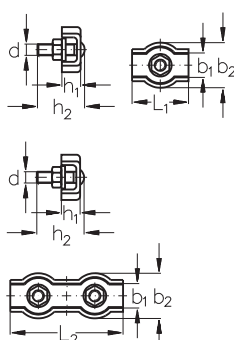
**Serre-câble plat INOX à 1 boulon**  
**Serre-câble plat INOX à 2 boulons**
**NIRO Simplex clip single box-type, with 1 screw**  
**NIRO Duplex clip double box-type, with 2 screws**

Désignation = Ø câble nominal size = rope-Ø mm	b <sub>1</sub> mm	b <sub>2</sub> mm	d	h <sub>1</sub> mm	h <sub>2</sub> mm	L <sub>1</sub> mm	L <sub>2</sub> mm	N° article stock no. 1 boulon Simplex	N° article stock no. 2 boulons Duplex
2	4	12	M 4	5	14	15	30	309 100 002	309 101 002
3	6	14	M 4	7	14	17	35	309 100 003	309 101 003
4	8	18	M 5	7	18	20	40	309 100 004	309 101 004
5	10	20	M 5	8	18	25	50	309 100 005	309 101 005
6	12	24	M 6	9	23	30	60	309 100 006	309 101 006
8	17	30	M 8	13	25	37	75	309 100 008	309 101 008
10	21	35	M 10	16	32	-	95	-	309 101 010

**Tendeur INOX à cage ouverte**  
à deux œils

**NIRO Turnbuckle open type**  
with eye and eye

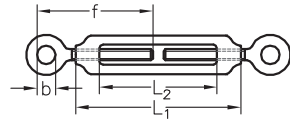

Désignation = Ø filetage nominal size = thread-Ø	Rupture * breaking load * kg	b mm	f mm	L <sub>1</sub> mm	L <sub>2</sub> mm	N° article stock no.	
M 5	400	7	50	70	55	308 500 005	
M 6	800	10	70	90	65	308 500 006	
M 8	1200	12	95	120	95	308 500 008	
M 10	1900	15	110	150	120	308 500 010	
M 12	3400	19	140	200	165	308 500 012	
M 16	5000	20	180	250	215	308 500 016	
M 20	8000	28	190	305	250	308 500 020	

\* Attention : ne pas confondre charge de rupture et charge utile.  
\* Please note that the above figures are breaking load limits and not working load limits.

**Tendeur INOX à cage ouverte**  
à œil et crochet

**NIRO Turnbuckle open type**  
with hook and eye

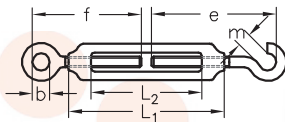

Désignation = Ø filetage nominal size = thread-Ø	Rupture * breaking load * kg	b mm	e mm	f mm	L <sub>1</sub> mm	L <sub>2</sub> mm	m mm	N° article stock no.	
M 5	100	7	55	50	70	55	6	308 501 005	
M 6	200	10	70	70	90	65	8	308 501 006	
M 8	350	12	95	95	120	95	9	308 501 008	
M 10	500	15	110	110	150	120	12	308 501 010	
M 12	1000	19	140	140	200	165	13	308 501 012	
M 16	1500	20	180	180	250	215	17	308 501 016	
M 20 <sup>3</sup> / <sub>4</sub> "	2000	28	195	190	305	250	20	308 501 020	

\* Attention : ne pas confondre charge de rupture et charge utile.  
\* Please note that the above figures are breaking load limits and not working load limits.

**Tendeur INOX à cage ouverte**  
à deux crochets

**NIRO Turnbuckle open type**  
with hook and hook

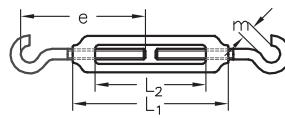

Désignation = Ø filetage nominal size = thread-Ø	Rupture * breaking load * kg	e mm	L <sub>1</sub> mm	L <sub>2</sub> mm	m mm	N° article stock no.	
M 5	100	55	70	55	6	308 502 005	
M 6	200	70	90	65	8	308 502 006	
M 8	350	95	120	95	9	308 502 008	
M 10	500	110	150	120	12	308 502 010	
M 12	1000	140	200	165	13	308 502 012	
M 16	1500	180	250	215	17	308 502 016	
M 20 <sup>3</sup> / <sub>4</sub> "	2000	195	305	250	20	308 502 020	

\* Attention : ne pas confondre charge de rupture et charge utile.  
\* Please note that the above figures are breaking load limits and not working load limits.



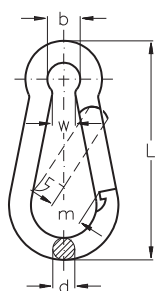

**Mousqueton INOX**
**NIRO Snap hook**

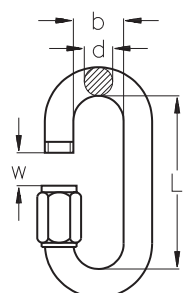
Désignation nominal size mm	b mm	d mm	L mm	m mm	w mm	N° article stock no.
50 x 5	8	5	50	7	4	309 200 050
60 x 6	9	6	60	9	5	309 200 060
70 x 7	11	7	70	8	8	309 200 070
80 x 8	12	8	80	9	8	309 200 080
100 x 10	15	10	100	12	10	309 200 100
120 x 11	18	11	120	16	11	309 200 120
140 x 12	21	12	142	23	17	309 200 140

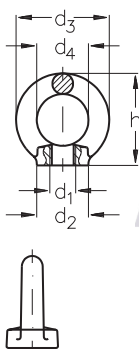

**Maillon rapide INOX**
**NIRO Quick link**

Désignation nominal size	b mm	d mm	L mm	w mm	N° article stock no.
4	10	4	33	5,5	309 300 004
5	12	5	39	6,5	309 300 005
6	13	6	45	7,5	309 300 006
7	16	7	53	8,5	309 300 007
8	16	8	59	10,0	309 300 008
10	20	10	70	12,0	309 300 010

**Anneau taraudé INOX**  
filetage à droite

**NIRO Eye nut**  
right hand thread

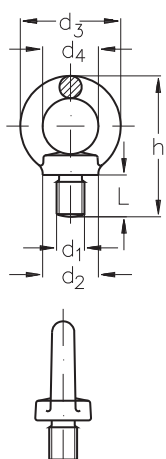
Désignation nominal size	d <sub>1</sub>	d <sub>2</sub> mm	d <sub>3</sub> mm	d <sub>4</sub> mm	h mm	N° article stock no.
M 6	M 6	15	26,5	15	27	308 111 006
M 8	M 8	20	36	20	36	308 111 008
M 10	M 10	25	45	25	45	308 111 010
M 12	M 12	30	54	30	53	308 111 012
M 16	M 16	35	63	35	62	308 111 016
M 20	M 20	40	72	40	71	308 111 020
M 24	M 24	50	89	50	90	308 111 024
M 30	M 30	60	107	60	109	308 111 030

**Anneau fileté INOX**  
filetage à droite

**NIRO Eye bolt**  
right hand thread

Désignation nominal size	d <sub>1</sub>	d <sub>2</sub> mm	d <sub>3</sub> mm	d <sub>4</sub> mm	L mm	h mm	N° article stock no.
M 6	M 6	15	26,5	15	10	37	308 110 006
M 8	M 8	20	36	20	13	49	308 110 008
M 10	M 10	25	45	25	17	62	308 110 010
M 12	M 12	30	54	30	20,5	73	308 110 012
M 16	M 16	35	63	35	26	90	308 110 016
M 20	M 20	40	72	40	30	101	308 110 020
M 24	M 24	50	89	50	35	125	308 110 024
M 30	M 30	60	107	60	45	132	308 110 030

Les éléments des pages 66 et 67 ne sont pas destinés au levage



**Manille INOX droite**
**NIRO Shackle, U-type**

Désignation nominal size	Rupture * breaking load * kg	d <sub>1</sub> mm	d <sub>2</sub> mm	d <sub>3</sub> mm	b <sub>1</sub> mm	h <sub>1</sub> mm	N° article stock no.
5	1200	5	5	10	10	17	308 400 005
6	1500	6	6	12	12	21	308 400 006
8	2500	8	8	16	16	28	308 400 008
10	4500	10	10	19	19	35	308 400 010
12	6000	11	12	24	23	41	308 400 012
13	7000	13	13	26	26	45	308 400 013
16	8000	15	16	32	31	55	308 400 016
19	12000	18	19	38	38	66	308 400 019
22	15000	21	22	44	45	76	308 400 022
25	18000	24	25	50	50	87	308 400 025

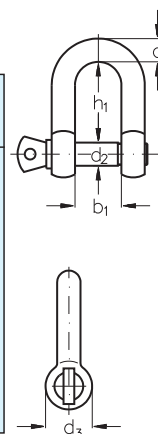

\* Attention : ne pas confondre charge de rupture et charge utile.  
 \* Please note that the above figures are breaking load limits and not working load limits.

**Manille INOX lyre**
**NIRO Shackle, anchor type**

Désignation nominal size	Rupture * breaking load * kg	d <sub>1</sub> mm	d <sub>2</sub> mm	d <sub>3</sub> mm	b <sub>1</sub> mm	b <sub>2</sub> mm	h <sub>1</sub> mm	N° article stock no.
4	500	4	4	8	8	14	18	308 300 004
5	1000	5	5	10	10	18	23	308 300 005
6	1600	6	6	12	12	21	27	308 300 006
8	2800	8	8	16	15	28	37	308 300 008
10	4000	10	10	20	19	35	46	308 300 010
12	5000	12	12	24	24	42	55	308 300 012

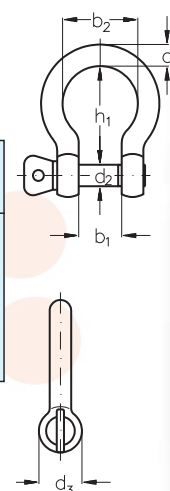

\* Attention : ne pas confondre charge de rupture et charge utile.  
 \* Please note that the above figures are breaking load limits and not working load limits.

**Chaîne INOX, maille courte**
**NIRO Short link chain**

Désignation nominal size	d mm	t mm	b mm	N° article stock no.
3	3	16,0	11	309 911 003
4	4	16,0	14	309 911 004
5	5	18,5	17	309 911 005
6	6	18,5	20	309 911 006
8	8	24,0	26	309 911 008
10	10	28,0	34	309 911 010

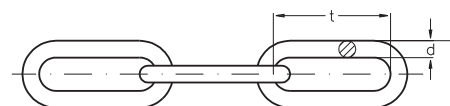

**Chaîne INOX, maille longue**
**NIRO Long link chain**

Désignation nominal size	d mm	t mm	b mm	N° article stock no.
3	3	26	13	309 910 003
4	4	32	16	309 910 004
5	5	36	20	309 910 005
6	6	42	24	309 910 006
8	8	54	32	309 910 008
10	10	66	40	309 910 010

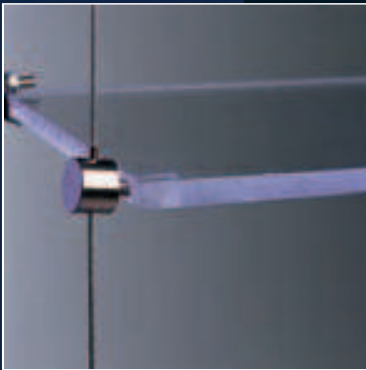
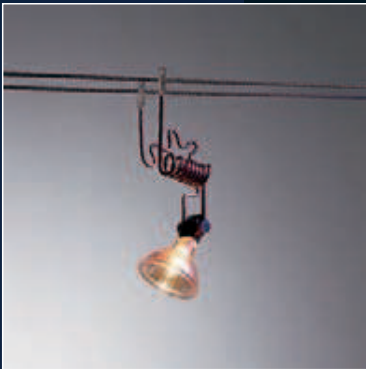

# ASS<sup>®</sup>

Système  
de Suspension  
*Hanging System*



Werkfoto: Schroers & Schroers, 10827 Berlin

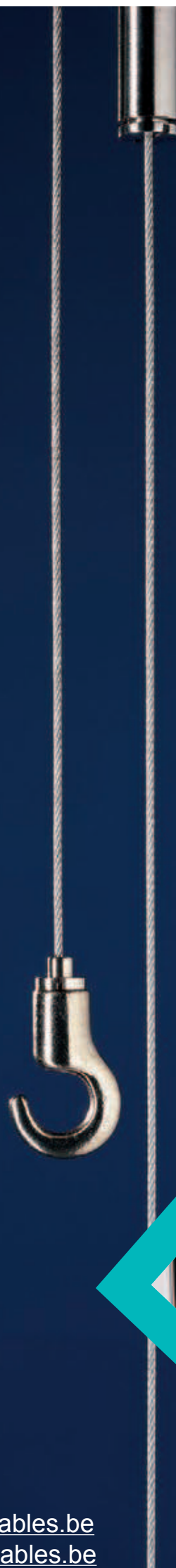

[www.lemmens-cables.be](http://www.lemmens-cables.be)  
[info@lemmens-cables.be](mailto:info@lemmens-cables.be)



## ASS Système de suspension

Malgré sa finesse, notre gamme **ASS** Mini et Super-Mini, utilisée à partir d'un câble de 3 mm est parfois, dans certains domaines d'application, surdimensionnée. Ceci est souvent le cas lorsque les charges à suspendre sont peu importantes.

Dans ce cas, nous vous conseillons d'utiliser nos Suspensions **ASS**.

Les tableaux par exemple, fixés par des câbles de seulement 1,5 mm paraissent flotter dans les airs et le regard ne sera pas dévié de l'essentiel.

Le montage de nos Suspensions **ASS** est tout à fait simple. Sans outil : régler, bloquer, monter ou échanger vite au moindre coût, ne sont que quelques-uns des avantages des Suspensions **ASS**.

Malgré un nombre limité de pièces, l'utilisation de notre gamme de Suspensions **ASS** offre d'innombrables possibilités.

Une élégance indémodable - pour des présentations professionnelles.

## ASS Hanging System

*Our **ASS** Stainless Steel System for architectural use is designed for wire ropes from 3 mm diameter and this is often too large for certain applications. We have therefore introduced our **ASS** Hanging System which enables wire rope of only 1.5 mm to be used for hanging pictures. The system is unobtrusive and the pictures appear to be floating.*

*The **ASS** Hanging System is easy to assemble without need for any tools, is infinitely variable, self locking, quickly adjusted and cost effective to replace. The many advantages of the system are readily apparent and whilst the number of components are few the variety of uses are unlimited.*

*Timeless elegance - For a professional presentation.*











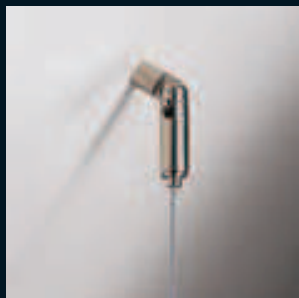
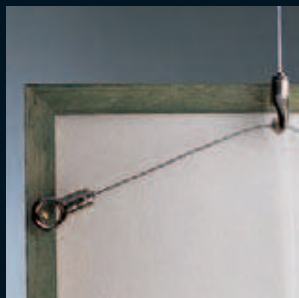
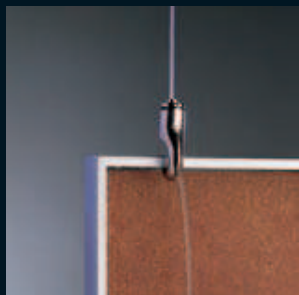
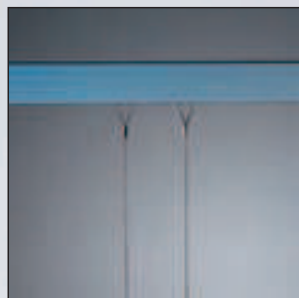

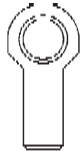

Schéma drawing	Désignation article	N° article stock no.		Schéma drawing	Désignation article	N° article stock no.	
	<b>Boucle manchonnée pour suspension</b> en Acier / Aluminium Rupt. 125 daN <i>Pressed eye</i>	387 010 001			<b>Câble spécial Haute Résistance</b> <b>Ø 1,5 mm</b> <i>Special wire rope</i> <b>Ø 1,5 mm high tensile</b>	387 010 014	
	<b>Crochet fil roulé à sertir</b> Acier zingué Rupt. environ 50 daN <i>Pressed bent hook</i>	387 010 006			<b>Suspension à crochet réglable</b> Acier coulé nickelé Rupt. 75 daN <i>Sliding hook</i>	387 010 003	
	<b>Œil fil roulé à sertir</b> Acier zingué Rupt. environ 50 daN <i>Pressed bent eye</i>	387 010 007			<b>Suspension à œil réglable</b> Acier coulé nickelé Rupt. 125 daN <i>Sliding eye</i>	387 010 002	
	<b>Œil fermé à sertir</b> Laiton nickelé Rupt. 125 daN <i>Pressed eye terminal</i>	387 010 016			<b>Suspension réglable à flasque</b> Laiton nickelé Rupt. 125 daN <i>Sliding cylinder with flange</i>	387 010 004	
	<b>Goutte de suif à sertir</b> Aluminium Rupt. 125 daN <i>Pressed domed end stop</i>	387 010 017			<b>Suspension à boule réglable</b> Laiton nickelé Rupt. 125 daN <i>Sliding ball</i>	387 010 008	
	<b>Embout fileté à sertir M 4 x 10</b> Acier zingué Rupt. environ 125 daN <i>Pressed threaded terminal</i>	387 010 018			<b>Suspension à crochet réglable</b> Laiton nickelé Rupt. 125 daN <i>Sliding shelves support, knurled</i>	387 010 019	

**Veillez prendre en note que les articles présentés aux pages 70 et 71 ne sont pas en Inox.**

**Please note the material.**

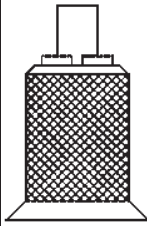
**The items on page 70 and 71 are not made of stainless steel material.**







Schéma drawing	Désignation article	N° article stock no.	
	<p><b>Suspension articulée réglable avec filetage intérieur ou extérieur</b> Laiton nickelé Rupt. 125 daN</p> <p><b>Sliding cylinder with internal or outside threaded link</b></p> <p>filetage intérieur <i>internal</i> M 5 M 6</p> <p>filetage extérieur <i>outside</i> M 5 M 6</p>	<p>387 011 005 387 011 006</p> <p>387 012 005 387 012 006</p>	
	<p><b>Attache plafond</b> Laiton nickelé Rupt. 125 daN</p> <p><b>Ceiling support</b></p>	387 010 009	
	<p><b>Douille-Arrêt à sertir pour attache plafond (sans câble)</b> Acier zingué Rupt. 125 daN</p> <p><b>Pressed nipple for ceiling support (without wire rope)</b></p>	387 010 020	
	<p><b>Suspension fileté réglable M 5, M 6, M 8</b> Laiton nickelé Rupt 125 daN</p> <p><b>Sliding cylinder with outside thread M 5, M 6, M 8</b></p>	<p>387 013 005 387 013 006 387 013 008</p>	
	<p><b>Suspension réglable avec filetage extérieur M 8 et écrou strié</b> Laiton nickelé Rupt. 200 daN</p> <p><b>Sliding cylinder with outside thread M 8 and knurled nut</b></p>	387 010 023	

Schéma drawing	Désignation article	N° article stock no.	
	<p><b>Rail de suspension 3 m</b> Aluminium verni</p> <p><b>Extruded picture support</b></p> <p>A l'achat de rail de suspension, nous vous livrons 5 crochets ainsi que le matériel d'assemblage.</p> <p><i>The extruded picture support will be delivered including 5 hooks and assembling material.</i></p>	387 010 011	
	<p><b>Crochet pour rail de suspension</b> Acier coulé zingué</p> <p><b>Picture hook</b></p>	387 010 012	
	<p><b>Support simple pour tablette</b> Laiton nickelé Rupt. 125 daN</p> <p><b>Sliding single shelf support</b></p>	387 010 021	
	<p><b>Support double pour tablette</b> Laiton nickelé Rupt. 125 daN</p> <p><b>Sliding double shelf support</b></p>	387 010 022	
	<p><b>Attache sol réglable</b> Laiton nickelé Rupt. 125 daN</p> <p><b>Floor support</b></p>	387 010 010	

**Tous les éléments ci-dessus sont à l'échelle 1:1**  
**All drawings scale 1:1**

Ne pas confondre charge de rupture (rupt.) et charge utile.  
Le calcul de la charge utile est le suivant : charge de rupture divisée par le coefficient de sécurité en vigueur.

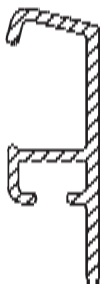
*Please note that the above figures are breaking load limits (BL) and not working load limits. To calculate the working load limit please divide the breaking load limit by the valid safety factor.*

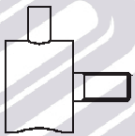
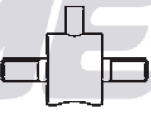
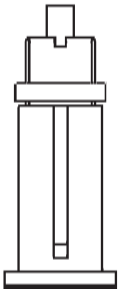
D'autres éléments sont disponibles sur demande.  
*Further types on request.*



NOTES







**ASS<sup>®</sup>**  
**MAXI**



Pour câbles Inox  
du diamètre 12 à 26 mm.

For stainless steel wire ropes  
diameter 12 up to 26 mm.  
[www.lemmens-cables.be](http://www.lemmens-cables.be)  
[info@lemmens-cables.be](mailto:info@lemmens-cables.be)



LA QUALITE EN ACIER INOXYDABLE

**DIAMETRE EXTERIEUR DES TERMINAISONS AVANT/APRES SERTISSAGE:**  
**DIAMETER OF THE TERMINAL BEFORE/AFTER PRESSING OR SWAGING:**

câble-Ø rope-Ø  mm	intérieur-Ø internal Ø d <sub>3</sub> mm	extérieur-Ø/outside-Ø d <sub>2</sub>	
		avant/before mm	apres/after mm
12	12,5	20,0	17,60 – 17,80
14	14,8	25,0	22,00 – 22,23
16	17,0	28,0	25,15 – 25,40
19	20,0	34,5	31,44 – 31,75
22	23,5	40,5	36,20 – 36,50
26	27,5	46,0	40,97 – 41,28

**CHARGES DE RUPTURE**  
**MINIMUM BREAKING LOADS**

Les charges de rupture indiquées dans ce catalogue sont valables pour l'article spécifié. Elles sont déterminées en fonction du filetage, de l'oeil, de la chape et de l'axe de chape.

L'utilisateur est responsable de la conformité du choix du câble ainsi que du bon sertissage.

*The minimum breaking loads given in this catalogue are applicable for the specified item. They are determined by the thread, eye or jaw and pin of the relevant item.*

*The user is responsible for the correct choice of rope and for correct swaging or pressing.*



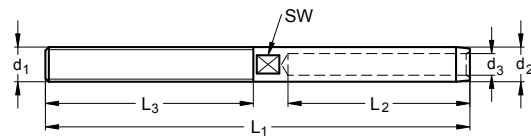

**ASS Maxi-Terminaison**  
filetage à droite ou à gauche

**ASS Threaded Terminal, Maxi type**  
with right and left hand thread

câble-Ø rope-Ø mm	Filetage thread d <sub>1</sub>	d <sub>2</sub> mm	d <sub>3</sub> mm	L <sub>1</sub> mm	L <sub>2</sub> mm	L <sub>3</sub> mm	SW mm	Charge de rupture* min. breaking load* kg	Filetage à droite right hand thread N° article stock no.	Filetage gauche left hand thread N° article stock no.
12	M 20	20,0	12,5	249	105	120	17	13.000	371 101 220	371 201 220
14	M 22	25,0	14,8	308	140	140	22	17.000	371 101 422	371 201 422
16	M 22	28,0	17,0	333	160	140	25	17.000	371 101 622	371 201 622
16	M 24	28,0	17,0	363	160	170	25	23.000	371 101 624	371 201 624
19	M 27	34,5	20,0	425	200	180	30	25.500	371 101 927	371 201 927
22	M 30	40,5	23,5	480	230	200	36	31.000	371 102 230	371 202 230
26	M 36	46,0	27,5	550	280	220	41	43.000	371 102 636	371 202 636

\* Attention à ne pas confondre Charge de Rupture et CMU.  
\* These figures are breaking load limits, not working load limits.

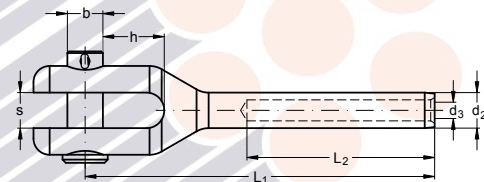

**ASS Maxi-Terminaison à chape, usinée**

**ASS Machined Jaw Terminal, Maxi type**

câble-Ø rope-Ø mm	d <sub>2</sub> mm	d <sub>3</sub> mm	L <sub>1</sub> mm	L <sub>2</sub> mm	h mm	s mm	b mm	Charge de rupture* min. breaking load* kg	N° article stock no.
12	20,0	12,5	197	105	35,5	20	19	13.000	371 021 012
14	25,0	14,8	239	140	38,0	22	22	17.000	371 021 014
16	28,0	17,0	271	160	39,3	25	25,4	24.000	371 021 016
19	34,5	20,0	327	200	41,0	30	28	25.500	371 021 019
22	40,5	23,5	377	230	51,0	35	32	31.000	371 021 022
26	46,0	27,5	434	280	49,5	35	35	43.000	371 021 026

\* Attention à ne pas confondre Charge de Rupture et CMU.  
\* These figures are breaking load limits, not working load limits.

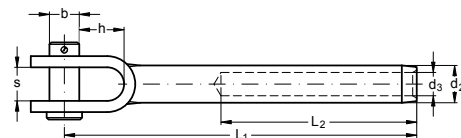

**ASS Maxi-Terminaison à chape, soudée**

**ASS Welded Jaw Terminal, Maxi type**

câble-Ø rope-Ø mm	d <sub>2</sub> mm	d <sub>3</sub> mm	L <sub>1</sub> mm	L <sub>2</sub> mm	h mm	s mm	b mm	Charge de rupture* min. breaking load* kg	N° article stock no.
12	20	12,5	189	105	41,0	24	19	13.000	371 020 012
14	25	14,8	232	140	46,5	30	22	17.000	371 020 014
16	28	17,0	264	160	49,5	30	25	24.000	371 020 016

Attention à ne pas confondre Charge de Rupture et CMU.  
\* These figures are breaking load limits, not working load limits.





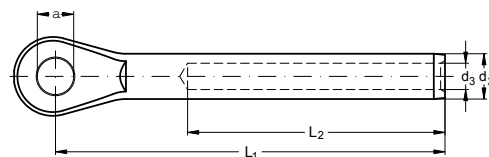

**ASS Maxi-Terminaison à oeil**

**ASS Eye Terminal, Maxi type**

câble-Ø <i>rope-Ø</i> mm	d <sub>2</sub> mm	d <sub>3</sub> mm	L <sub>1</sub> mm	L <sub>2</sub> mm	a mm	s mm	Charge de rupture* <i>min. breaking load*</i> kg	N° article <i>stock no.</i>
12	20	12,5	156	105	19,3	15	13.000	371 025 012
14	25	14,8	205	140	23	18	17.000	371 025 014
16	28	17,0	232	160	26	20	24.000	371 025 016
19	34,5	20,0	302	200	28,5	25	27.000	371 025 019
22	40,5	23,5	348	230	33	30	31.000	371 025 022
26	46	27,5	400	280	36	30	43.000	371 025 026

\* Attention à ne pas confondre Charge de Rupture et CMU.

\* These figures are breaking load limits, not working load limits.

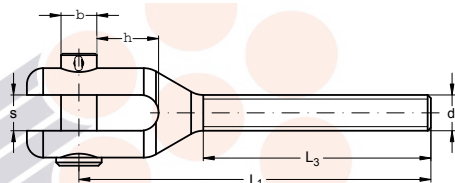

**ASS Maxi-Chape fileté, usinée**  
filetage à droite ou à gauche

**ASS Machined Threaded Jaw, Maxi type**  
with right and left hand thread

Désignation <i>nominal size</i>	Filetage <i>thread</i> d <sub>1</sub>	L <sub>1</sub> mm	L <sub>3</sub> mm	h mm	s mm	b mm	Charge de rupture* <i>min. breaking load*</i> kg	Filetage à droite <i>right hand thread</i> N° article <i>stock no.</i>	Filetage à gauche <i>left hand thread</i> N° article <i>stock no.</i>
M 20	M 20	219,5	125	35,5	20	19	13.000	371 522 020	371 523 020
M 22	M 22	216	140	38,0	22	22	17.000	371 522 022	371 523 022
M 24	M 24	255	170	39,3	25	25	20.000	371 522 024	371 523 024
M 27	M 27	274	180	41,0	30	28	25.500	371 522 027	371 523 027
M 30	M 30	316	200	51,0	35	32	31.000	371 522 030	371 523 030
M 36	M 36	334	220	49,5	35	35	43.000	371 522 036	371 523 036

\* Attention à ne pas confondre Charge de Rupture et CMU.

\* These figures are breaking load limits, not working load limits.

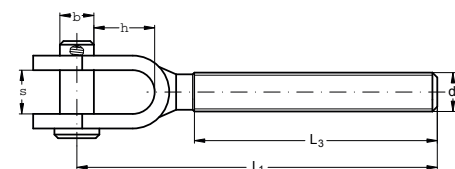

**ASS Maxi-Chape fileté, soudée**  
filetage à droite ou à gauche

**ASS Welded Threaded Jaw, Maxi type**  
with right and left hand thread

Désignation <i>nominal size</i>	Filetage <i>thread</i> d <sub>1</sub>	L <sub>1</sub> mm	L <sub>3</sub> mm	h mm	s mm	b mm	Charge de rupture* <i>min. breaking load*</i> kg	Filetage à droite <i>right hand thread</i> N° article <i>stock no.</i>	Filetage à gauche <i>left hand thread</i> N° article <i>stock no.</i>
M 20	M 20	193	120	41,0	24	19,0	13.000	371 520 020	371 521 020
M 22	M 22	224,5	140	46,5	30	22,0	17.000	371 520 022	371 521 022
M 24	M 24	258	170	49,3	30	25,4	20.000	371 520 024	371 521 024

\* Attention à ne pas confondre Charge de Rupture et CMU.

\* These figures are breaking load limits, not working load limits.

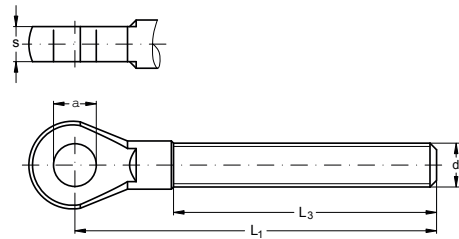

**ASS Maxi-Oeil**  
filetage à droite

**ASS Threaded Eye, Maxi type**  
with right hand thread

Désignation nominal size	Filetage thread d <sub>1</sub>	L <sub>1</sub> mm	L <sub>3</sub> mm	a mm	s mm	Charge de rupture* min. breaking load* kg	N° article stock no.
M 20	M 20	164	120	19,5	15	13.000	371 510 020
M 22	M 22	196,5	140	23,0	18	17.000	371 510 022
M 24	M 24	230	170	25,5	20	20.000	371 510 024
M 27	M 27	247,5	180	28,5	25	25.500	371 510 027
M 30	M 30	274	200	32,5	30	31.000	371 510 030
M 36	M 36	297	220	35,5	30	43.000	371 510 036

Attention à ne pas confondre Charge de Rupture et CMU.

\* These figures are breaking load limits, not working load limits.

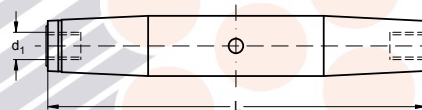
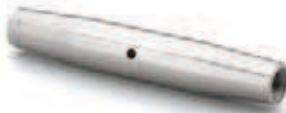

**ASS Maxi-Corps de ridoir**  
Avec bague taraudée en bronze  
Garantissant une utilisation durable  
même sous forte charge

**ASS Rigging Screw - body, Maxi type**  
Internal thread made of bronze  
This guarantees longterm use,  
even under heavy load.

Désignation nominal size	Filetage thread d <sub>1</sub>	L mm	Charge de rupture* min. breaking load* kg	N° article stock no.
M 20	M 20	240	13.000	371 213 020
M 22	M 22	270	17.000	371 213 022
M 24	M 24	325	20.000	371 213 024
M 27	M 27	345	25.500	371 213 027
M 30	M 30	375	31.000	371 213 030
M 36	M 36	410	43.000	371 213 036

\* Attention à ne pas confondre Charge de Rupture et CMU.

\* These figures are breaking load limits, not working load limits.

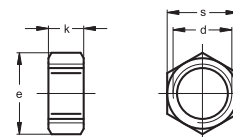

**ASS Maxi-Ecrous**  
filetage à droite ou à gauche

**ASS Lock Nut, Maxi type**  
with right and left hand thread

Désignation nominal size	Filetage thread d <sub>1</sub>	e mm	s mm	k mm	Filetage à droite right hand thread N° article stock no.	Filetage à gauche left hand thread N° article stock no.
M 20	M 20	27,7	24	13,0	371 010 020	371 011 020
M 22	M 22	34,6	30	16,5	371 010 022	371 011 022
M 24	M 24	41,6	36	17,5	371 010 024	371 011 024
M 27	M 27	47,3	41	22,0	371 010 027	371 011 027
M 30	M 30	53,1	46	24,0	371 010 030	371 011 030
M 36	M 36	63,5	55	29,0	371 010 036	371 011 036

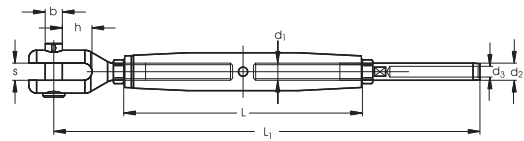

**ASS Maxi-Ridoir**

chape (usinée, filetage à gauche) et terminaison

Avec bague taraudée en bronze

**ASS Rigging Screw, Maxi type**

with jaw (machined) and terminal

Internal thread made of bronze

câble-Ø rope-Ø mm	Filetage thread d <sub>1</sub>	d <sub>2</sub> mm	d <sub>3</sub> mm	h mm	s mm	b mm	L mm	L <sub>1</sub> mm	Charge de rupture* min. breaking load* kg	N° article stock no.
12	M 20	20,0	12,5	35,5	20	19	240	489,5	13.000	371 241 220
14	M 22	25,0	14,8	38	22	22	270	547	17.000	371 241 422
16	M 22	28,0	17,0	38	22	22	270	572	17.000	371 241 622
16	M 24	28,0	17,0	39,5	25	25	325	638	20.000	371 241 624
19	M 27	34,5	20,0	41	30	28	345	728	25.500	371 241 927
22	M 30	40,5	23,5	51	35	32	375	819	31.000	371 242 230
26	M 36	46,0	27,5	49,5	35	35	410	906	43.000	371 242 636

\* Attention à ne pas confondre Charge de Rupture et CMU.

\* These figures are breaking load limits, not working load limits.

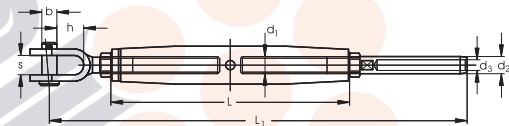

**ASS Maxi-Ridoir**

chape (soudée, filetage à gauche) et terminaison

Avec bague taraudée en bronze

**ASS Rigging Screw, Maxi type**

with jaw (welded) and terminal

Internal thread made of bronze

câble-Ø rope-Ø mm	Filetage thread d <sub>1</sub>	d <sub>2</sub> mm	d <sub>3</sub> mm	h mm	s mm	b mm	L mm	L <sub>1</sub> mm	Charge de rupture* min. breaking load* kg	N° article stock no.
12	M 20	20	12,5	41,0	24	19	240	466	13.000	371 251 220
14	M 22	25	14,8	46,5	30	22	270	555,5	17.000	371 251 422
16	M 22	28	17,0	46,5	30	22	270	580,5	17.000	371 251 622
16	M 24	28	17,0	49,3	30	25,4	325	641	20.000	371 251 624

\* Attention à ne pas confondre Charge de Rupture et CMU.

\* These figures are breaking load limits, not working load limits.

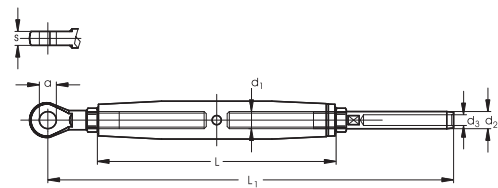

**ASS Maxi-Ridoir**

oeil (filetage à droite) et terminaison

Avec bague taraudée en bronze

**ASS Rigging Screw, Maxi type**

with eye and terminal

Internal thread made of bronze

câble-Ø rope-Ø/thread mm	Filetage mm d <sub>1</sub>	d <sub>2</sub> mm	d <sub>3</sub> mm	a mm	s mm	L mm	L <sub>1</sub> min. breaking load*	Charge de rupture* min. breaking load* kg	N° article stock no.
12	M 20	20,0	12,5	19,5	15	240	439	13.000	371 271 220
14	M 22	25,0	14,8	23	18	270	527,5	17.000	371 271 422
16	M 22	28,0	17,0	23	18	270	552,5	17.000	371 271 622
16	M 24	28,0	17,0	25,5	20	325	613	20.000	371 271 624
19	M 27	34,5	20,0	28,5	25	345	701,5	25.500	371 271 927
22	M 30	40,5	23,5	32,5	30	375	777	31.000	371 272 230
26	M 36	46,0	27,5	35,5	30	410	869	43.000	371 272 636

\* Attention à ne pas confondre Charge de Rupture et CMU.

\* These figures are breaking load limits, not working load limits.



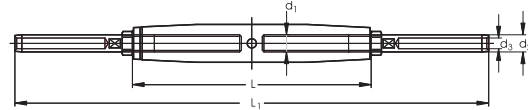

**ASS Maxi-Ridoir**

deux terminaisons

Avec bague taraudée en bronze

**ASS Rigging Screw, Maxi type**

with terminal and terminal

Internal thread made of bronze

câble-Ø rope-Ø mm	Filetage thread d <sub>1</sub>	d <sub>2</sub> mm	d <sub>3</sub> mm	L mm	L <sub>1</sub> mm	Charge de rupture* min. breaking load* kg	N° article stock no.
12	M 20	20,0	12,5	240	524	13.000	371 261 220
14	M 22	25,0	14,8	270	639	17.000	371 261 422
16	M 22	28,0	17,0	270	689	17.000	371 261 622
16	M 24	28,0	17,0	325	746	20.000	371 261 624
19	M 27	34,5	20,0	345	879	25.500	371 261 927
22	M 30	40,5	23,5	375	983	31.000	371 262 230
26	M 36	46,0	27,5	410	1122	43.000	371 262 636

\* Attention à ne pas confondre Charge de Rupture et CMU.

\* These figures are breaking load limits, not working load limits.

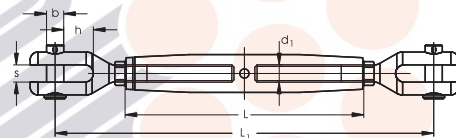

**ASS Maxi-Ridoir**

deux chapes (usinées)

Avec bague taraudée en bronze

**ASS Rigging Screw, Maxi type**

with jaw and jaw (machined)

Internal thread made of bronze

Désignation nominal size	Filetage thread d <sub>1</sub>	h mm	s mm	b mm	L mm	L <sub>1</sub> mm	Charge de rupture* min. breaking load* kg	N° article stock no.
M 20	M 20	35,5	20	19	240	455	13.000	371 220 020
M 22	M 22	38	22	22	270	455	17.000	371 220 022
M 24	M 24	39,5	25	25	325	530	20.000	371 220 024
M 27	M 27	41	30	28	345	577	25.500	371 220 027
M 30	M 30	51	35	32	375	665	31.000	371 220 030
M 36	M 36	49,5	35	35	410	690	43.000	371 220 036

\* Attention à ne pas confondre Charge de Rupture et CMU.

\* These figures are breaking load limits, not working load limits.

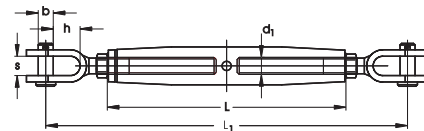

**ASS Maxi-Ridoir**

deux chapes (soudées)

Avec bague taraudée en bronze

**ASS Rigging Screw, Maxi type**

with jaw and jaw (welded)

Internal thread made of bronze

Désignation nominal size	Filetage thread d <sub>1</sub>	h mm	s mm	b mm	L mm	L <sub>1</sub> mm	Charge de rupture* min. breaking load* kg	N° article stock no.
M 20	M 20	41	24	19	240	408	13.000	371 230 020
M 22	M 22	46,5	30	22	270	472	17.000	371 230 022
M 24	M 24	49,3	30	25,4	325	536	20.000	371 230 024

\* Attention à ne pas confondre Charge de Rupture et CMU.

\* These figures are breaking load limits, not working load limits.

